



Chhattisgarh State Renewable Energy Development Agency(CREDA)

(Dept. of Energy, Govt. of Chhattisgarh)
Near Energy Education Park, Village Fundhar
VIP (Air Port Road) Raipur 492015 (C.G.)
Ph.: +91-8370009931

E-mail: contact.creda@gov.in, Website: creda.co.in
BID DOCUMENT No. 13366/CREDA/BID/RE-III/SPVPP/2019
DT. 06-11-2019

TENDER FOR STANDARDISATION OF RATES FOR SURVEY, DESIGN, SUPPLY, INSTALLATION AND COMMISSIONING OF OFF GRID SOLAR POWER PLANT WITH LMLA & LITHIUM FERRO PHOSPHATE BATTERY BANK WITH HYBRID PCU OF CAPACITY RANGING FROM 600W TO 120KW WITH FIVE YEARS ON SITE AND UNCONDITIONAL WARRANTEE ANYWHERE IN THE STATE OF CHHATTISGARH.

Particulars	From Date & Time	To Date & Time	Place
Date of issue of notice inviting bid	06-11-2019 05:00 pm	----	----
Period of availability of bidding document at website	02-03-2020 05:00 pm	08-04-2020 05:00 pm	http://www.creda.co.in
Pre Bid Meeting & submission of queries in writing	07-03-2020 11:00 am	07-03-2020 05:00 pm	At H.O. CREDA, RE-III, Section
Inspection of Materials by Bid Committee as per Valid Test Report and Submission of Summary of Test Report and M.A.F.	19-03-2020 11:00 am	19-03-2020 05:00 pm	At Ground Near H.O. CREDA, VIP Road, Raipur
Submission of Technical Bid	24-03-2020 11:00 am	24-03-2020 05:00 pm	At H.O. CREDA, RE-III, Section.
Submission of e-Price Bid	24-03-2020 11:00 am	07-04-2020 05:00 pm	http://www.cspc.co.in
Opening of Technical Bid	08-04-2020 11:00 am	08-04-2020 03:00 pm	At H.O. CREDA, RE-III, Section
Declaration of Eligible Bidder	08-04-2020 05:00 pm	----	At H.O. CREDA, RE-III, Section
Opening of e- Price Bid	09-04-2020 11:00 am	09-04-2020 05:00 pm	At H.O. CREDA, RE-III, Section

Bid Document Cost– Rs.10,000.00 + 18% GST = Rs.11,800.00
(in words Rupees Eleven Thousand Eight Hundred Only)

Document can also be downloaded from our website www.creda.co.in with the cost of Bid as mentioned in NIT, which shall have to be deposited along with the Bid document.

CHATTISGARH STATE RENEWABLE ENERGY DEVELOPMENT AGENCY

CONTENTS

S.No.	Description	Page No.
1	Cover Page, Contents etc.	1-3
2	Notice Inviting BID	4-5
3	Check List	6
4	Details of EMD and Bid Fee	7
5	Undertaking of the Bidder	8
	SECTION - 1	9-16
6	Instruction For Bidder ,Eligibility Criteria	9-10
7	Consortium/Start-Up/New Entrepreneur/Bidding Process	11
8	EMD/Submission of Documents/Specific /Amendments/GST&TIN/ RMS/Bid	12
9	Analysis of Rate/Registration of Bidder etc.	13
10	CREDA reserves the right/ Communications/ Bid Document Fee and Earnest Money/ Submission / Display of/ Pre-bid Meeting Samples/ Jurisdiction of the court ETC.	14-16
	SECTION - 2	17-24
11	General Condition of Contract	17
12	Definitions/Proof of Manufacturer/Contract Document/Manner	17
13	Variations, Additions & Omissions/Inspection	18
14	Eligible SI Default Liability/Force Majeure/Rejection of works/Completion work etc.	19-24
	SECTION - 3	25-26
15	Scope of Work	25-26
	SECTION - 4	27-70
16	Specifications For Solar Photovoltaic Power Plants	27
17	General Technical Specification:	27
18	Minimum Technical Requirements/Standards	28
19	Modules	28
20	Battery	29-31
21	PCU	31-32
22	Balance of System (BOS) Items/Components	33
23	Module Mounting Structure	33
24	Battery Trolley Rack/ Electrical connection/ Junction Boxes	34
25	Lightning and Over voltage protection/Surge protection device	35
26	Earthing Protection/ DCDB/ACDC/ Danger Boards	36
27	Cables/Wire/ Junction Boxes/Tool Kit	37

28	Data Acquisition System / Plant Monitoring/Other Features/ Installation of System	38
29	Electric Cable/ Warranty/ Traceability of the Product to be Supplied/ Specifications of Elevated Structure	39-40
30	WARRANTY AND MAINTENANCE	41
31	Technical Bid	42-43
32	E-Price Bid	44-46
33	Draft Agreement Annexure-XII	47-50
34	PART 'A': GENERAL INFORMATION (Schedule – I)	51
35	PART 'B' : COMMERCIAL INFORMATION (Schedule – II)	52
36	PART 'C' : TECHNICAL INFORMATION (Schedule – III)	53
37	TECHNICAL DEVIATIONS (Schedule – IV)	54
38	PAST EXPERIENCE (Schedule – V)	55
39	ANNEXURE – XIII	56
40	Consortium Agreement ANNEXURE – XV	57-59
41	Benchmark cost of solar Power Plant as per CREDA and Form A,B &C for Survey ANNEXURE – XVI	60
42	Complete Drawing of Elevated Module Mounting Structure& Civil Works	61-72

Ref. No.13366/CREDA/HOR/RE-III/SPVPP/Bid/2019

Date : 06-11-2019

NOTICE INVITING TENDER

CREDA invites sealed Bids for Survey, design, supply, installation, and commissioning of Solar Photovoltaic power plant with LMLA & Lithium Ferro phosphate battery bank with hybrid PCU with five years COMC, onsite warrantee, Insurance for anywhere in the State of Chhattisgarh from registered System integrators of CREDA for SPV with 3 years track record in Solar photovoltaic power plants, as per following details -

Sl.No.	Category	Item Description	Cost of Bid Document	EMD	Essentials
		Supply, Installation and commissioning of solar power plant with LMLA & Lifep04 battery bank with hybrid PCU of capacity			
		Module cap./Battery Bank Cap./Battery Bank Voltage			
1	A	600W/120AH/24V	Rs 10,000.00 +18% GST = Rs.11,800.00	Rs.5,00,000.00	As per clause no. 1A to 1F of Eligibility Criteria (Page no.9-10)
2		1200W/120AH/48V			
3		2400W/240AH/48V			
4		3000W/400AH/48V			
5		3600W/360AH/48V			
6	B	4800W/240AH/48V			
7		6000W/300AH/96V			
8		7200W/360AH/96V			
9		9000W/ 600AH/ 120V			
10		10500W/ 600AH/ 120V			
11		12000W/480AH/120V			
12	C	15000W/400AH/240V			
13		18000W/360AH/240V			
14		21000W/400AH/240V			
15		24000W/480AH/240V			
16		30000W/600AH/240V			
17		36000W/720AH/240V			
18		48000W/960AH/240V			
19		51000W/800AH/240V			
20		60000W/1200AH/240V			
21		80000W/1200AH/240V			
22		102000W/1000AH/240V			
23		120000W/1200AH/240V			
24		120000W/2400AH/240V			
TOTAL -			11,800.00	5,00,000.00	----

Important Events and time schedule for this Bid are as follows –

Particulars	From Date & Time	To Date & Time	Place
Date of issue of notice inviting bid	06-11-2019 05:00 pm	----	----
Period of availability of bidding document at website	02-03-2020 05:00 pm	08-04-2020 05:00 pm	http://www.creda.co.in
Pre Bid Meeting & submission of queries in writing	07-03-2020 11:00 am	07-03-2020 05:00 pm	At H.O. CREDA, RE-III, Section
Inspection of Materials by Bid Committee as per Valid Test Report and Submission of Summary of Test Report and M.A.F.	19-03-2020 11:00 am	19-03-2020 05:00 pm	At Ground Near H.O. CREDA, VIP Road, Raipur

Submission of Technical Bid	24-03-2020 11:00 am	24-03-2020 05:00 pm	At H.O. CREDA, RE-III, Section.
Submission of e-Price Bid	24-03-2020 11:00 am	07-04-2020 05:00 pm	http://www.cspc.co.in
Opening of Technical Bid	08-04-2020 11:00 am	08-04-2020 03:00 pm	At H.O. CREDA, RE-III, Section
Declaration of Eligible Bidder	08-04-2020 05:00 pm	----	At H.O. CREDA, RE-III, Section
Opening of e- Price Bid	09-04-2020 11:00 am	09-04-2020 05:00 pm	At H.O. CREDA, RE-III, Section

Price Bid shall be submitted online only at <http://www.cspc.co.in>, however Technical bid will have to be submitted in hard copy at Chief Engineer (RE – III) Section, Near Energy Education Park VIP Road, Raipur. Bidders are advised to follow the instructions provided for Registration and e-Submission Process accordingly. (for any query about e-bidding please visit user manual at <http://www.cspc.co.in>.)

Details of this Bid are mentioned at Bid Documents which can be downloaded from our website www.creda.co.in. The Bidder should have to deposit Bid document cost along with EMD as mentioned above through demand draft payable to CREDA Raipur while submitting Bid.

Bidders are requested to attend Pre-Bid meeting with their suggestions/objections/ reservations if any with details so as to avoid any confusion and to ensure clarity and transparency regarding the Bid.

CREDA reserves all rights to accept/reject any or all Bids in full/part without assigning any reasons.

**Chief Engineer
RE-III,H.O.
CREDA
Raipur (CG)**

Details of bank account for RTGS/ NEFT :

Name	CREDA
Bank & Branch Name	ICICI Bank, Pachpedi Naka, Raipur
Bank Account Number	134601000400
Branch IFSC Code	ICIC0001346

CHECK LIST

To ensure that your Bid submitted to CREDA is complete in all respects, please go through the following checklist & tick mark for the enclosures attached with your Bid –

Sl. No.	Description	Complied	Page No. / Flag
1.	Earnest Money Deposit		
2.	Bid Document Fee (proof of submission)		
3.	The original document duly signed & with stamp on each page, as a confirmation of acceptance of Terms & Conditions (T&C).		
4.	Copy of Registration: Certificate as System Integrator of CREDA in SPV Programme valid for FY 2019-20.		
5	Copy of Approved and valid Test Reports of components of SPVPP in the name of Bidder/Manufacturer.		
5.1	SPV Modules		
	a) IEC 61215 edition II/ IS 14286 for Crystalline Modules		
	b) IEC 61730 Part 1 & 2		
	c) STC Performance Report –I V curve.		
5.2	Batteries- MNRE/NABAL/BIS authorized test centres		
5.3	PCU cum inverters- MNRE/NABAL/BIS authorized test centres		
6	Original Net Worth Certificate and Turnover Certificate duly signed by Chartered Accountant		
7	Completion and Performance Certificates of SPV power plants installed by the Bidder in Govt Scheme of any state or Market Mode Scheme of CREDA.		
8	Proof of being Eligible Manufacturer of Modules/ PCU/Batteries/other BOS.		
9.	Copy of certificate for last three years turnover of works done regarding SPVPP.		
10.	Declaration of conflict of interest - by bidder about any relatives working with CREDA.		
11.	Manufacture Authorization certificates of major components of solar power plants.		
12.	Forwarding Letter & Undertaking by the Bidder		
13.	PAN, GSTIN, Copy of ITRs for last three FY of the Bidder		
14.	Undertaking on indigenoussness of components		
15.	Self-certificate from Bidder on not being a debarred from Government contract or a blacklisted company.		
16.	Undertaking for the remaining test reports of components (for which acknowledgements have been submitted) submission within 90 days from the date of agreement.		
17.	Original copy of agreement in case of consortium bidders		

Details of EMD and Bid Fee

Sl. No.	Description
1.	Earnest Money Deposit - Earnest Money Deposit of Rs., submitted in the form of Demand Draft / Banker's Cheque/RTGS/NEFT from any scheduled bank drawn on _____ Bank _____ Branch, bearing DD/BC No. _____ dated _____ is attached herewith.
2.	Bid Document Fee - Bid Document Fee of Rs., submitted in the form of Demand Draft / Banker's Cheque/RTGS/NEFT from any scheduled bank drawn on _____ Bank _____ Branch, bearing DD/BC No. _____ dated _____ is attached herewith.

(Sign & Seal of the Bidder/Manufacturer)

UNDERTAKING OF THE BIDDER

I/We have read carefully and examined the notice inviting Bid, schedule, General Rules and terms and conditions of the contract, special conditions, Schedule of Rates and other documents and Rules referred to in the Bid document for the supply.

I/We hereby Bid my rates for the execution of the work for CREDA as specified within the time stipulated in the schedule in accordance with all aspects with the specifications, designs, drawings and instructions with such conditions so far as applicable.

I/We agree to keep the Bid valid for **One Hundred Eighty (180) days** from the due date of submission thereof and not to make any modifications in its terms and conditions.

A sum of **Rs.....** is hereby forwarded as **Earnest Money** in the form of crossed demand draft / RTGS / NEFT payable to CREDA at Raipur (C.G.). If I/We fail to commence or complete the Work Ordered in specified time or fail to fulfil the any condition of Bid document, I/We agree that the CREDA shall, without prejudice to any other right or remedy, be at liberty to forfeit the said Earnest Money absolutely. The said Earnest Money shall be retained by CREDA towards security deposit to execute all the works referred to in the Bid documents upon the terms and conditions contained or referred to therein and to carry out such deviations as may be required by CREDA.

I/We hereby declare that I/We shall treat the Bid documents, specifications and other records connected with the work as secret/confidential and shall not communicate information derived there from to any person other than a person to whom I/We have authorized to communicate the same or use the information in any manner prejudicial to the safety of CREDA/Government.

I/We shall abide to all the laws and shall be responsible for making payments of all the taxes, duties, levies and other Govt. dues etc. to the appropriate Govt. departments.

Our GST Registration No. The PAN No. under the Income Tax Act is

I/We shall be responsible for the payment of the respective taxes to the appropriate authorities and should I/we fail to do so, I/we hereby authorize CREDA to recover the taxes due from us and deposit the same with the appropriate authorities on their demand.

Dated:

Signature

Place:

Name of Bidder with seal.....

Witness:

Signature:

Name:

Postal Address:

.....

SECTION - 1

INSTRUCTIONS FOR BIDDERS

1. ELIGIBILITY CRITERIA :

A. TEST REPORTS:

Tenderer must have valid test report of the integrated systems or their major component in the name of manufacturer. They will have to provide copy of such test report of the integrated systems or their major component from Solar Energy Test Centre or any other test centre approved by Ministry of New & Renewable Energy (MNRE)/ NABL. Tenderer must also have to submit test reports of all the major components such as SPV Module, Battery, and PCU cum Inverter.

Bidders may submit Acknowledgement of submission of materials along with make, capacity & numbers of Solar Module, Battery and PCU cum Inverter, **fee receipt from MNRE/NABL approved test centres for testing (in case they don't have approved test certificates of system at the time of bid)**. Bidders shall be required to submit the approved test certificates before raising claim for payment else payment shall not be made to them.

Financial bid of those Tenderers will not be opened who have not submitted valid test report/ Acknowledgement.

Bidders shall have to submit the Test certificate against Acknowledgement within 90 days of execution of agreement otherwise EMD may be forfeited and bidder may be blacklisted / debarred by CREDA. However this time limit may be further extended / reduced by CREDA if required.

Bidder should have test certificate/Acknowledgement for system valid at the time of opening of the bid.

B. MINIMUM EXPERIENCE

Bidders must have minimum experience in last three financial years i.e. 2016-17, 2017-18 & 2018-19 as per the details mentioned below –

S.No.	Category	Sub Category	for Bidders of Chhattisgarh state	for Bidders of Other States	For Start Ups and New Entrepreneurs	Mandatory Eligibility
A	B	C	D	E	F	G
1	Category-A	A(I)	The bidder must have the experience of installation and commissioning of SPVPP with Lifepo4 battery bank of Minimum 100KW(installed and	The bidder must have the experience of installation and commissioning of SPVPP with Lifepo4 battery bank of Minimum 200KW(installed and commissioned) capacity	Not allowed	Must have installed at least one system of 5KW capacity and Minimum capacity of system is restricted to150W
		A(II)	The bidder must have the experience of installation and commissioning of SPVPP with LMLA battery bank of Minimum 100KW(installed and	The bidder must have the experience of installation and commissioning of SPVPP with LMLA battery bank of Minimum 200KW(installed and commissioned) capacity	Not required	Must have installed at least one system of 5KW capacity and Minimum capacity of system is restricted to 01 KW
2	Category-B	B(I)	The bidder must have the experience of installation and commissioning of SPVPP with Lifepo4 battery bank of Minimum 300KW(installed and	The bidder must have the experience of installation and commissioning of SPVPP with Lifepo4 battery bank of Minimum 500KW(installed and commissioned) capacity	Not allowed	Must have installed at least one system of 10 KW capacity and Minimum capacity of system is restricted to150W
		B(II)	The bidder must have the experience of installation and commissioning of SPVPP with LMLA battery bank of Minimum 300KW(installed and	The bidder must have the experience of installation and commissioning of SPVPP with LMLA battery bank of Minimum 500KW(installed and commissioned) capacity		Must have installed at least one system of 10 KW capacity and Minimum capacity of system is restricted to01KW

3	Category-C	C(I)	The bidder must have the experience of installation and commissioning of SPVPP with Lifepo4 battery bank of Minimum 1000KW(installed and	The bidder must have the experience of installation and commissioning of SPVPP with Lifepo4 battery bank of Minimum 1500KW(installed and commissioned) capacity	Not allowed	Must have installed at least one system of 25 KW capacity and Minimum capacity of system is restricted to 150W
		C(II)	The bidder must have the experience of installation and commissioning of SPVPP with LMLA battery bank of Minimum 1000KW(installed and	The bidder must have the experience of installation and commissioning of SPVPP with LMLA battery bank of Minimum 1500KW(installed and commissioned) capacity		Must have installed at least one system of 25 KW capacity and Minimum capacity of system is restricted to 01KW

Bidders will have to submit satisfactory commissioning/functioning report containing complete system details from the concerned state/central agencies /department along with bid document. All these SPVPP systems should in successful operation as on date. (Experience in terms of works done for other private / non Govt. companies/ firms etc. shall not be considered). **Bidder registered as a Pvt. Ltd. / Ltd. / Partnership / Proprietorship firm incorporated / registered in the State of Chhattisgarh shall be treated as Bidder of Chhattisgarh.**

- C. Experience Certificates submitted should be in attached format (as per annexure-XIII) or Other Format containing similar information as in attached format (annexure-XIII) shall be considered only in-case of submitted in Hindi / English Language only. Work order, L.O.I. / L.O.A etc., will not be acceptable.
- D. Bidders must have a Positive Net worth of **Category “A”- Rs.15 Lacs, Category”B”- Minimum Rs.50 Lacs, Category “C” Rs.1 Crore as on 31st March 2018 (which is defined as “Net value of the Assets minus(-) Net value of liabilities”)**. They shall have to submit a **Original Certificate** duly signed by a qualified and registered Chartered Accountant having UDI number as a proof. Produced certificate must tally with the audited balance sheet.
- E. Bidders should have an aggregate turnover of **Category “A”-Minimum Rs.1.5 Crore, Category’B”-Minimum Rs.5 Crore, Category “C”-Minimum Rs.10 Crore** in last three years i.e. 2015-16, 2016-17 & 2017-18 in SPV Projects. Certified copies of the annual returns and audited balance sheet submitted to the Registrar of Companies/ Income Tax Authorities should be enclosed. For the preceding years a **Original Summarised Sheet** of turnover certified by registered CA must be enclosed.
- F. Any bidder willing to apply one or two or all categories in that case the turnover and experience should be cumulative i.e. for all category. As stated under:-

S.No.	Category	for Bidders of Chhattisgarh state	for Bidders of Other States	Turnover(In crore) for three FY i.e. 2015-16, 2016-17, 2017-18 (Minimum)	Net worth (In crore) as on 31 st march 2018 (Minimum)
1	A&B	Experience of I&C of Min 400KW	Experience of I&C of Min 700KW	Rs.6.5 Crore	Rs.0.65 Crore
2	B&C	Experience of I&C of Min 1300KW	Experience of I&C of Min 2000KW	Rs.15 Crore	RS.1.50 Crore
3	A&C	Experience of I&C of Min 1100KW	Experience of I&C of Min 1700KW	Rs.11.5 Crore	Rs.1.15 Crore
4	A&B&C	Experience of I&C of Min 1400KW	Experience of I&C of Min 2200KW	Rs.16.5 Crore	Rs.1.65 Crore

- G. Bidder who are debarred from business by Govt. /Govt. Agency in any state would not be eligible to participate in this bid. A self-declaration should be submitted by the bidder to this effect, failing which bid shall be rejected.
2. **CONSORTIUM** - Consortium will be allowed in this Bid up to 2 partners subject to fulfilling following criteria -
- (i) Both the partners should jointly fulfil eligibility criteria as per clause 1B, 1D and 1E.
 - (ii) The lead partner should fulfil criteria as per clause 1C individually and other partner should have Positive Net worth as on 31st March 2018. For Positive Net worth of other partner Audited balance sheet must be enclosed.
 - (iii) Both the partners should individually fulfil criteria of 1F.
 - (iv) If either partner submits any alternate / individual bid then both bids (individual & consortium) shall be rejected.
 - (v) The Consortium agreement notarized in Non Judicial stamp paper of Rs. 100 as per draft given in annexure-"XV" must be submitted along with the bid documents.
 - (vi) In Consortium if one or both the partners are from Chhattisgarh then they should have minimum experience of as **per point 1B column D** and if both the partners are from outside the state then they should have minimum experience as **per point 1B column E**.
3. **START-UP AND NEW ENTREPRENEUR** -
- A. CREDA may consider awarding work of installation up to **5 Solar Power Plant Systems** on **L-1** price to Start-up & New Entrepreneur.
 - B. **START-UP**- CREDA may consider Start-up Company registered only in area of Solar PV modules/Batteries/Solar power plants/Solar inverters and PV System integrator, if it produces certificate of being a Start-up entities as issued by Government of India.
 - C. **NEW ENTREPRENEUR**- (New Entrepreneur means System Integrator who doesn't fulfil the eligibility criteria as per clause 1A to 1E). CREDA shall consider Companies/Proprietorship firm/Partnership firm which are registered in CREDA as NEW ENTREPRENEUR.
 - D. EMD of **Rs. 1.00 Lacs** in form of D.D.
 - E. Start -up & New Entrepreneur Bidder must have valid test report of all components such as solar modules, hybrid PCU, Batteries which he is going to use in the solar power plants. They will have to provide copy of such Test reports or Acknowledgement of components of solar power plants from test centre approved by Ministry of New and Renewable Energy (MNRE) or NABL/BIS.
 - F. Start -up & New Entrepreneur are not allowed to Quote Prices.
 - G. Maximum **10%** of the total work may be reserved for start-up and new entrepreneur.
4. **BIDDING PROCESS** -
- For ease of accessing the e-bidding website and registration the following is to be done by bidder -
- A. Visit <http://www.cspc.co.in>
 - B. Click on e-bidding button on right hand side of the page.
 - C. The user will be directed to e-bidding page where all information regarding registration is available along with helpline details.
 - D. Price Bid shall be submitted online only at <http://www.cspc.co.in> however technical bid will have to be submitted in hard copy. Bid Documents (including Technical Bid) must reach at Chief Engineer (RE-III) Section, Near Energy Education Park VIP Road, Raipur latest by **05.00 PM on 24-03-2020**. Bids submitted after scheduled time and date shall not be considered.

5. EMD, TECHNICAL BID AND SAMPLES -

Document Fee, EMD, Technical Bid, test reports of components, SPV Modules, LA & Earthing, batteries ,ACDB,DCDB,AJB ,Hybrid PCU and Structures should be submitted for examination from **11:00 am to 05:00 PM dated 24-03-2020** at Ground near CREDA Head office Raipur. These will be examined by Technical Committee of CREDA on **08-04-2020** and Bidders will be shortlisted on the basis of approval of the Technical bids and samples along with Test Report for opening of price bids.

6. SUBMISSION OF DOCUMENTS -

Documents should be submitted in prescribed manner in separate envelopes as follows-

- A.** Main Envelope: Main Envelope must enclose all A, B, C & D envelopes. Bidder Name, Address and status of firms should be clearly written on main envelope. In case the bidder is participating as “CONSORTIUM” Name and address of both Partners with Title as “CONSORTIUM” must be mention on main envelope. Start-up or New Entrepreneur must mention title as “Start-up” or “New Entrepreneur” as applicable on main envelope.
- B.** Envelope-(A): Bid Fees and EMD.
- C.** Envelope-(B): Financial Eligibility Documents: Net worth & Turnover certificate as per clause 1C & 1D & 1E.
- D.** Envelope-(C): Technical Eligibility Documents: Experience certificates, Test Reports & Summary of Test Reports and Manufacturer Authorization Form as per clause 1A, 1B & 1E.
- E.** Envelope-(D): Complete Bid document in original duly seal & signed by authorized signatory on each & every page of the Bid document.
- F.** The category for the bidder wants to bid must be clearly mentioned in the top of **Envelope D**

Bid Document which doesn't follow the above format shall be disqualified.

7. SPECIFICATION AMENDMENTS -

The Specifications of SPV Modules, Hybrid PCU, Battery LMLA & Lifepo4, Structures, Earthing LA, ACDB,DCDB,AJB,MJB etc should be as per as Specified in the Bid. If any amendments are issued by CREDA in due course of time, in this context, then those shall be applicable under this Bid.

8. GST & PAN -

Bidder shall have to submit copies of GST registration number and PAN numbers issued by the appropriate authority.

9. RMS /DATA LOGGER -

Login ID & Password of RMS/Data Logger shall be mentioned in each JCC and all data will have to be shared at suitable platform provided by CREDA as and when required..

10. THE BID -

Technical Bid must be deposited in the Bid box only kept in the Chief Engineer RE-III Section, CREDA, H.O., Raipur **from 11:00 am 24-03-2020 to 05:00 PM dated 24-03-2020** nobody is authorized to receive or grant receipt for Bid delivered on behalf of CREDA. Bid received through any other means shall not be considered.

11. ANALYSIS OF RATE -

A. Bidder should quote their rates considering variation of site conditions and all other factors in price of different components and keeping the quantum and quality of work in mind. Every care has been taken in preparing the cost estimation i.e. Benchmark Cost (Annexure – XVI) however, these are for guidance purpose only.

B. The benchmark cost of CREDA is Exclusive of GST and the bidder has to quote the price without GST. The rates will be compared without GST.

C. If the successful bid is unbalanced in relation to the benchmark cost of CREDA as stated in Annexure-XVI by less than 10%, the successful bidder shall have to provide Additional Performance Security (APS) to the extent of difference of 90% of benchmark cost and rates quoted by the successful bidder for total allocable quantity in such categories in which he has submitted unbalanced bid, in the form of Demand Draft/RTGS issued by approved scheduled bank in favour of CREDA, before signing the agreement. The same shall be released along with the normal SD after 05 years of agreement. In case the bidder refuse to deposit Additional Performance Security (APS) then his bid will be rejected by the sanctioning authority and earnest money shall be forfeited and shall be blacklisted /debarred to participate in any tender/ activity of CREDA till further orders. In such case CREDA shall have discretionary rights to decide reasonable rates in comparison to benchmark costs which may be rates quoted by L2 if found reasonable.

If the bidder fails to complete the work or left the work incomplete, this Additional Performance Security (APS), S.D. and EMD shall be forfeited by the CREDA and the agreement shall be terminated and bidder shall be blacklisted /debarred to participate in any tender/ activity of CREDA till further orders.

D. Those Bidders who have accepted the L1 rate also required to submit additional performance security for allocated work.

12. REGISTRATION OF BIDDER –

Bidders should have a valid registration certificate of System Integrator in CREDA in SPV programme for FY 2019-20. Bidders who are not registered with CREDA, upon allocation of work shall register himself as system integrator of CREDA within 30 days of such allocation failing which work allocation shall stand cancelled without any further notice in this regard and allocation work shall be re-allocated to other parties as per Bid condition. In case of Consortium both the partners will have to get registered as SI in CREDA.

13. VALIDITY -

Full descriptive particulars and complete specifications should accompany the offer. Offers should be kept open for acceptance for at least **180 days** from the date of opening. After finalization of this Bid the approved rates shall be valid till one year from the date of award; however CREDA shall have liberty to increase or decrease this validity if needed.

14. TERMS & CONDITIONS -

A. The terms, conditions and specifications mentioned in Bid document shall be binding on the Bidders and no condition or stipulation contrary to the conditions shall be acceptable. It may please be noted that the Bidders who do not accept terms and conditions stipulated in this Bid documents, their offers shall be liable to be rejected out-rightly without assigning any reason whatsoever.

B. Each page of Bid document & enclosures shall be signed by the Bidder and seal affixed. All the pages of the documents issued must be submitted along with the technical offer. In case of any corrections / alterations in the Bid, the Bidder should attest the same; otherwise Bids may not be considered. In case of Consortium both the partners shall sign & seal.

C. Bidders are also instructed to submit their Bids in properly arranged manner (with index, proper paging and with flags on important documents). Incomplete, lose, conditional or improper arranged Bids will not be accepted.

15. CREDA RESERVES THE RIGHT -

- (i) To reject or accept any or all Bids fully or partly without assigning any reason on the grounds considered advantageous to CREDA, whether it is the lowest Bid or not.
- (ii) To split the quantities against the Bid further for the same items/work. No reason will be assigned by CREDA for this and will be binding on the Bidders.
- (iii) To increase or decrease of aggregate quantities up to 100 % as per discretion or circumstances.
- (iv) Due to large quantum of work & limitation of the time period for completion of the work CREDA may take consent from other Bidders if they agree to work on rates standardized by CREDA.
- (v) CREDA may undergo agreement with those eligible Bidders who give consent to work on rates standardized by CREDA and may allocate work to them. Rates approved through this Bid may be standardized for all eligible Bids to work in **year 2019-20** and shall be valid till **31-03-2021**. However CREDA reserves right to curtail or extend this period.

16. COMMUNICATIONS -

- A. All the communication between Bidder and CREDA shall be in writing. Notice sent by Fax or other Electronic means shall be effective on confirmation of the transmission. Notice sent by registered post or speed post shall be effective of delivery or at expiry of normal delivery period as under taken by Postal Service.
- B. Offers through Telegraph/Fax/Emails/Post/Courier or open offers etc. received shall be summarily rejected.

17. BID DOCUMENT FEE AND EARNEST MONEY-

- A. Each Bidder should submit Bid Document Fee and earnest money in the form of Demand Draft/Pay Order or RTGS/NEFT as mentioned in the NIT vide **13366/CREDA/HOR/RE-III/SPVPP/2019 DT. 06-11-2019**, in a separate envelope as prescribed at **point no.06 of page 12**, else they will summarily be rejected and returned. Bid Document Fee & EMD submitted in any other form e.g. **Cash/Bank Guarantee/FDR /TDR etc. shall not be accepted.**
- B. MSME unit registered for manufacturing or service of solar power plants or components in Chhattisgarh state and public sectors of government are exempted from EMD subjected to submission of valid document.

18. SUBMISSION / DISPLAY OF SAMPLES -

Bidders will have to provide samples of their Module, Hybrid PCU, LMLA & Lifep04 Battery (or single cell), Structures, ACDB,DCDB,AJB,MJB, LA & Chemical Earthing Kit, B.O.S. and etc. All components should be submitted for examination before **01:30 PM on 19-03-2020** at Ground near H.O. CREDA, VIP Airport Road, Raipur. These samples shall be examined by Technical Committee of CREDA.

19. PRE-BID MEETING -

- A. A pre-bid meeting shall be organized on **07-03-2020 at 11:00 AM** at Raipur to explain the terms & conditions of the Bid and to clarify doubts of the Bidders so that all doubts and confusions are resolved before the Bid is submitted. Only one authorized representative of the parties who fulfils the primary eligibility conditions as mentioned in NIT and desire to purchase/download the Bid document shall be allowed to participate in the said meeting. Amendments/clarifications, if any arising during pre-bid meet, shall be uploaded on **www.creda.co.in**. It is advisable for all Bidders to attend this Pre Bid Meeting.
- B. All suggestions, doubts, confusion, request, queries etc., shall have to be presented to CREDA in writing on or before **07-03-2020 till 5:00 PM**. After that any representation in this regard shall not be considered.

- C. The purpose of pre-bid meeting will be clarifying issues and to answer questions in any matter that can be raised at that stage. Minutes of the meeting and the responses given will be uploaded for information of bidders. Any modification of the bidding document which may become necessary as a result of pre-bid meeting shall be part of original Bid document and communicated through corrigendum.

20. TECHNICAL CRITERIA -

- A. Tenderer must have valid test report of the integrated systems in the name of manufacture . They will have to provide copy of such test report of the integrated systems from Solar Energy Test Centre or any other test centre approved by Ministry of New & Renewable Energy (MNRE)/ NABL. Tenderer must also have to submit test reports of all the major components such as SPV Module, Battery, and PCU cum Inverter. Therefore tenderer shall have to submit independent test reports of each major components used.

Bidders may submit Acknowledgement of submission of materials along with make, capacity & numbers of Solar Module, Battery and PCU cum Inverter, **fee receipt from MNRE/NABL approved test centres for testing (in case they don't have approved test certificates of system at the time of bid)**. Bidders shall be required to submit the approved test certificates before raising claim for payment else payment shall not be made to them.

Financial bid of those Tenderers will not be opened who have not submitted valid test report/ Acknowledgement.

Bidders shall have to submit the Test certificate against Acknowledgement within 90 days of execution of agreement otherwise EMD may be forfeited and bidder may be blacklisted / debarred by CREDA. However this time limit may be further extended / reduced by CREDA if required.

Bidder should have test certificate/Acknowledgement for system valid at the time of opening of the bid.

- B. The Bidder should have sufficient technically qualified and well-experienced manpower for execution of the project and after sales service of the systems. These details may be called by CREDA and in case there is any deficiency found the Bidder may be debarred.

21. FORFEITURE OF EARNEST MONEY DEPOSIT -

It should be clearly understood that in the event of Bidder failing to enter into the agreement in the prescribed format on their quoted rates and also fails to execute assigned works under any Scheme of CREDA, within stipulated time, if he is so communicated within the validity period of the offer, the full amount of earnest money will be forfeited and Bidder shall be debarred from future business with CREDA. CREDA's decision in this regard will be final and binding on the Bidders.

22. PRICE OF SUPPLY OF SOLAR POWER PLANTS WITH INSTALLATION, COMMISSIONING AND TESTING. -

- I. The Price quoted for all models of each category solar power plant systems with installation, commissioning and testing, of SPV Modules, Hybrid PCU, LMLA & Lifepo4 battery bank, Lightening arrester, earthing, Civil works and all other required BOS like Cables, Suitable Nut Bolts etc. with 5 years system warranty, insurance. The GST shall be paid extra as per prevailing rate. The prices shall be filled exactly as per **e-Price Bid enclosed**.
- II. Any change in GST shall be become applicable during the period of contract.
- III. In this regard if there is any change in the composition ratio of goods and services by any Authority/ Courts, same shall be applicable.

23. ENGINEERING DOCUMENT -

Bidders will have to submit Engineering Documents with technical details, drawings, Specifications of components and make etc. to CREDA for approval, as and when asked by CREDA. Works may only be started out only after approval of the Engineering Document and their samples.

24. SAMPLES -

Samples of the components shall have to be submitted to the CREDA in prescribed manner on scheduled date.

25. INSPECTIONS -

CREDA reserves right to inspect the material at Godowns / Temporary Stores before dispatch and also at works sites.

26. TAX OBLIGATIONS -

CREDA shall deduct TDS for Income Tax, applicable cess on Civil Work etc. under various acts and deposited with the appropriate authority. Costs and taxes before execution of agreement with CREDA so as to ensure tax deposition as per Government Rules accordingly.

27. JURISDICTION OF THE COURT -

Any dispute arising out of the contract shall be subject to the jurisdiction of Hon'ble High Court of Chhattisgarh.

SECTION - 2

GENERAL CONDITIONS OF CONTRACT

1. DEFINITIONS -

In writing General Conditions of Contract, the specifications and bill of quantity, the following words shall have the meanings hereby indicated, unless there is something in the subject matter or content inconsistent with the subject.

- CREDA shall mean the Chhattisgarh State Renewable Energy Development Agency represented through the Chief Engineer.
- Work shall mean any work entrusted to the Bidder as mentioned in the scope of work and Work Order.
- The "Engineer in charge" shall mean the Engineer or Engineers authorized by CREDA for the purpose of this contract. Inspecting Authority shall mean any Engineering person or personnel authorized by CREDA to supervise and inspect the erection of the SPVPP.
- "The Eligible SI/Bidder" shall mean the Bidder awarded with the contract or their successors and permitted assigns. Contract Price shall mean the sum named in or calculated in accordance with the provisions of the contract as the contract price. General Conditions shall mean the General conditions of Contract.
- "Specifications" shall mean the specifications annexed to these General Conditions of contract and shall include the schedules and drawings attached thereto or issued to the eligible SI from time to time, as well as all samples and pattern, if any,
- "Month" shall mean calendar month. "Writing" shall include any manuscript, typewritten, printed or other statement reproduced in any visible form whether under seal or written by hand.

2. PROOF OF MANUFACTURER -

Those bidders who are also manufacturers of an important component of SPVPP such as SPV Modules, PCU, Structures of SPVPP and Batteries shall have to submit proof of their factory, SSI Registration and list of Machineries and Equipment's.

3. CONTRACT DOCUMENT -

The term "Contract" shall mean and include the General conditions, specifications, schedules, drawings and Work Orders etc., issued against the contract schedule of price or their final general conditions, any special conditions applying to the particular contract specification and drawings and agreement to be entered into. Terms and conditions not herein defined shall have the same meaning as are assigned to them in the Indian contract Act or any other Act in vogue or by any person of common knowledge and prudence.

4. MANNER OF EXECUTION -

- A. Execution of work shall be carried out under Government Mode Scheme of CREDA in an approved manner as outlined in the technical specifications or where not outlined, in accordance with desired Specifications laid down by CREDA, to the reasonable satisfaction of the Engineer.
- B. Successful Bidder / Bidder here-in-after called the **SI** (System Integrator).
 - i) After receipt of LOI from CREDA the eligible SI shall conduct a detailed survey of site and submit site details in prescribed format after due verification and signatures of AE/EE/Officer In Charge of CREDA. All necessary documents and survey details shall have to be submitted in concerned District Office of CREDA in prescribed manner. SI shall also have to submit site clearance, NOC for its use and a layout plan duly consented and signed jointly by him and AE/EE/Officer In Charge of CREDA.
 - ii) Engineer-in-Charge of District Office of CREDA shall examine these Survey

report. After his satisfaction will forward details with his recommendations to EE of Concerned Regional Office of CREDA. Engineer-in-charge may visit the site if he/she is not satisfied with survey report.

- iii) In case Engineer-in-Charge of District Office of CREDA finds the site not suitable for installation of SPVPP he/she will inform concerned beneficiary organisation / department accordingly and request for alternative site /necessary action.
- iv) Executive Engineer of concerned Regional Office CREDA will decide the technical feasibility and layout plan of site. Executive Engineer may visit the site if he/she is not satisfied with survey report.
- v) After satisfaction Executive Engineer will forward the site clearance report with technical feasibility to Head Office CREDA for issuance of work orders.
- vi) HO CREDA will be final authority to approve or reject site finalisation recommended by Regional Offices.
- vii) Concerned Chief Engineer of CREDA after his satisfaction shall issue the work order to eligible SI for installation of SPVPP.
- viii) Work order will be given to the chosen System Integrator only after execution of the agreement with CREDA.
- ix) After issuance of Work Orders Executive Engineer of concerned Regional Office CREDA will finally approve site layout in writing in prescribed format.
- x) The SI shall start work within **15 days** after the date of approval of site layout.
- 4.1 All the materials required for the installation of SPVPP as per Work Order issued shall be kept at site in the custody of the SI. CREDA shall not be responsible for any loss or damage of any material during the installation.
- 4.2 All the electrical works should be done as per various provisions of Indian Electricity Act. The persons engaged for carrying out electrical works should have a valid **B-class** license or above issued by licensing board of Chhattisgarh.
- 4.3 After installation joint inspection will be done in presence of beneficiary, SI and CREDA and after successful commissioning of SPVPP and its approval from CREDA a JCC will be signed and forwarded for payments as per guidelines and procedures of CREDA.

5. VARIATIONS, ADDITIONS & OMISSIONS -

CREDA shall have the right to alter, amend, omit, split or otherwise vary the quantum of work, by notice in writing to the SI. The eligible SI shall carry out such variation in accordance with the rates specified in the contract so far as they may apply and where such rates are not available; those will be mutually agreed between CREDA and the eligible SI.

6. INSPECTION -

- A. The Engineer-in-Charge or his authorized representative(s) shall be entitled at all reasonable times to inspect and supervise and test during installation and commissioning. Such inspection will not relieve the eligible SI from their obligations under this contract.
- B. Material can be inspected before dispatch or in transit by the authorized representatives of CREDA at the factory / godown at the cost of the eligible SI, if desired by CREDA.
- C. CREDA will undertake real time performance and quality test of randomly selected solar power plant and components during the course of execution as per the specifications and guidelines laid by CREDA to ensure quality and performance of solar power plants and its components.

7. COMPLETION OF WORK -

Time being the essence of contract, the installation of the SPVPP shall be completed within the time schedule prescribed in the Work Order.

8. ELIGIBLE SYSTEM INTEGRATOR'S DEFAULT LIABILITY -

CREDA may by written notice of default to the eligible SI, terminate the contract in circumstances detailed hereunder -

- (a) If in the opinion of the CREDA, the eligible SI fails to complete the work within the time specified in the Work Order or within the period for which extension has been granted by CREDA to the eligible SI.
- (b) If in the opinion of CREDA, the eligible SI fails to comply with any of the provisions of this contract.
- (c) In the event of CREDA terminating the contract in whole or in part as provided in paragraph (a) above, CREDA reserves the right to engage another eligible SI or agency upon such terms and in such a manner as it may deem appropriate and the eligible SI shall be liable to CREDA for any additional costs or any losses caused to CREDA as may be required for the completion of erection of the SPVPP and or for penalty as defined under this Bid document until such reasonable time as may be required for the final completion of the work.
- (d) In the event CREDA does not terminate the contract as provided in paragraph (a) the eligible SI shall continue performance of the contract, in which case he shall be liable to CREDA for penalty for delay as set out in this Bid document until the work is completed.

9. FORCE MAJEURE -

The eligible SI shall not be liable for any penalty for delay or for failure to perform the contract for reasons of FORCE MAJEURE such as of God, acts of public, enemy, LWE problems, acts of government, cyclone, fires, floods, epidemics, quarantine restrictions, strikes, freight embargoes provided that if SI shall submit delay notice with appropriate cause of delay to the CREDA in writing within **15 days** of force majeure. CREDA shall verify the facts and may grant such extension as facts justify. Delay in supply of any accessories of Solar power plants etc. by the related vendors, to whom the Bidder has placed order, shall also not be treated as force majeure.

10. REJECTION OF WORKS -

In the event of any of the material supplied/work done by the eligible SI is found defective in material or workman ship or otherwise not in conformity with the requirements of this contract specifications, CREDA shall either reject the material and/or work and advise the eligible SI to rectify the same. **CREDA may impose penalty for such rejection up to the 200% cost of the entire system. Habitual/repeated offenders shall be black listed/debarred to participate in the any Bid/ Activity of CREDA till further orders.** The eligible SI on receipt of such notices shall rectify or replace the defective material and rectify the work free of cost. If the eligible SI fails to do so CREDA may -

- a) At its option replace or rectify such defective materials and/or work and recover the extra cost so involved from the eligible SI plus **15%** service charges of the cost of such rectification, from the eligible SI and/ or terminate the contract for balance work/ supplies with enforcement of penalty **as stated above.**
- b) Defective materials/workmanship will not be accepted under any conditions and shall be rejected outright without compensation. The eligible SI shall be liable for any loss/damage sustained by CREDA due to defective work **with enforcement of penalty as stated above.**

11. EXTENSION OF THE TIME -

If the completion of installation is delayed due to any reason beyond the control of the eligible SI, the eligible SI shall without delay give notice to the CREDA in writing of his claim for an extension of time. CREDA on receipt of such notice may or may not agree to extend the contract/delivery date of the Solar System as may be reasonable but without prejudice to other terms and conditions of the contract.

12. **MAKES OF EQUIPMENTS TO BE USED IN THE WORK -**

- (I) The Solar Modules, PCU, Batteries & Other BOS shall be made in India.
- (II) It will be mandatory to use indigenously manufactured solar modules with indigenous mono/multi crystalline silicon cell. Further, the PCU, batteries and balance of systems should also be manufactured indigenously. The manufacturer has to declare the list of imported components used in the solar power Plants.
- (III) The eligible SI has to ensure that equipment's as per Technical Requirements of guidelines of CREDA as complied with. The eligible SI has also to ensure that he will use only components of approved vendors of CREDA. The material/works for which CREDA/MNRE or BSI or ISI specification is not available, engineer-in-charge of the works will examine and approve the material/works, preferably of all makes on which CREDA has report of satisfactory performance. Test certificates for all major equipment's should be submitted to the engineer-in-charge of the works before installation of the same.
- (IV) Successful SI upon issue of LOI must submit Manufacture Authorization Form (MAF) From manufacture of Solar Module/ PCU/ Battery/BOS which it is intending to use during installation guarantee at least five year warrantee of PCU, Batteries and other BOS and at least 10 year warrantee on module, before installation of SPVPP, no payment shall be made if he fails to do so.
- (V) SI Should submit warrantee Agreement of **at least 5 years** for major components i.e. SPV Modules, Inverter/PCU, Batteries and BOS with manufacturer or distributors certified by the manufacturer before installation of SPVPP for any manufacturing defects or bad workmanship.

13. **WARRANTEE PERIOD AND POST INSTALLATION SERVICES -**

- A. The work done/material supplied by the eligible SI should be warranted for satisfactory operation and against any defect in material and workmanship including solar PCU, Batteries and Structures and other balance of equipment's, at least for a period of **5 (five) years**, from the date of commissioning of the SPVPP other works as per scope of work.
- B. Warrantee on SPV Modules shall be for **10 (ten) years** from the date of commissioning of the SPV power plants must be warranted for their output peak watt capacity, which should not be less than **90%** at the end of **10 years** and not less than **80%** at the end of **25 years**.
- C. The above warrantee certificates shall be furnished to the CREDA for approval. Any defect noticed during this period should be rectified by the supplier free of cost upon written notice from CREDA provided such defects may be due to bad workmanship or bad materials used.
- D. The warrantee period shall be extended by the period during which the plant remains non-operative due to reasons within control of the eligible SIs.
- E. This warrantee must be an unconditional onsite warrantee and the eligible SI will have to replace the defective material within **7 days** positively from the date of information given to him.
- F. Care should necessarily be taken to make the SPVPP operational, once the reporting of the fault/non-operational status is done, within a week. If the SPVPP is not made operational within **7 days** CREDA may rectify the same at the cost of SI and the warrantee period shall be extended for a month for the same.
- G. System Integrators shall have to establish their service stations in the allocated area and shall have to keep sufficient quantity of spares and man power to ensure proper service network for taking care of smooth functioning of SPVPP installed by them. SI shall have to give a toll free number to register complaints.

14. TERMS OF PAYMENT -

The following terms of payment shall apply for the Bid -

- A. 95%** of the eligible payment as per the Work Order after satisfactory supply, installation, commissioning & performance test of the SPVPP at site with proper handing over.
- B. Balance 5%** of the eligible payment shall be retained by CREDA as Performance Security for a period of **60 months**.

15. PENALTY FOR DELAY IN COMPLETION OF CONTRACT -

If the eligible SI fails to complete the assigned work within the schedule time specified in the Work Order or any extension granted there to, CREDA will recover from the SI as penalty a sum of **One per cent (1%)** of the system price excluding GST/Tax for every delayed system per month. For this purpose, the date of taking over shall be reckoned as the date of completion. The total penalty shall not exceed **5% (Five Per cent)** of the cost.

Review of the progress of installation of SPVPP allocated to SIs shall be done time to time by CREDA and if the progress of installation is found unsatisfactory, the allocation of entire remaining uninstalled SPVPP or their part of can be re-allocated to other SI as per discretion of CREDA.

16. SECURITY DEPOSIT (SD) -

- A.** The Earnest Money shall be retained by CREDA up to the validity of TENDER, after agreement is done to execute all the works referred to in the Bid documents upon the terms and conditions contained or referred to therein and to carry out such deviations as may be required by CREDA.
- B.** Beside this **5%** of the cost shall also be retained as SD during the five years of warrantee period. No interest shall be payable on the Security Deposit.
- C.** Period for which EMD and SD are to be retained may be extended in case the warrantee period is extended due to non performance of the system.

17. INSURANCE -

- A.** The eligible SI shall arrange insurance coverage for the materials and SPVPP system at his/ beneficiary's custody for the work under execution and successful commissioning and subsequent handover to the beneficiary. The eligible SI shall take up insurance or such other measures for the manpower so as to cover the claim for damage / accident under workmen's compensation Act and other applicable State/Central laws. CREDA shall not bear any responsibility on this account.
- B.** Eligible SI shall arrange for insurance coverage for complete SPVPP during warrantee period i.e. for **05 years** from the date of installation/commissioning. Insurance should cover for damage and theft. In case of such incidence, SI must replace the lost/damaged part within **7 days** from the date of intimation.

18. PENALTY DUE FROM THE ELIGIBLE SI -

All costs of damages and delays for which the eligible SI is liable to the CREDA will be deducted from any money due to the eligible SI including the security deposit of any project under CREDA.

19. ELIGIBLE SI'S RESPONSIBILITY -

Notwithstanding anything mentioned in the specifications of subsequent approval or acceptance of the SPVPP by CREDA, if any, the ultimate responsibility for satisfactory performance of the entrusted work shall rest with the eligible SI. If in any case the eligible SI does not complete the work as per the Work Orders issued to them then CREDA may take over the task & complete the project at the risk and cost of eligible SI.

20. RESPONSIBILITY TO RECTIFY THE LOSS AND DAMAGE -

If any loss or damage occurs to the work or any part thereof or materials/plant/equipment's for incorporation therein the period for which the eligible SI is responsible for the cause thereof or from any cause whatsoever, the eligible SI shall at his own cost rectify/replace such loss or damage, so that the permanent work confirms in every respect with the provision of the contract to the satisfaction of the Engineer. The eligible SI shall also be liable for any loss or damage to the work/equipment's occasioned by him in course of any operation carried out to him during performing the contract.

21. RESPONSIBILITY TOWARDS THE WORKMAN OR OUTSIDERS –

- A. The eligible SI shall have to take insurance coverage from any authorized Insurance Company against Workmen compensation due under Workmen Compensation Act and submit copy of the insurance document before issuance of Work Order.**
- B.** The eligible SI shall ensure all safety measures during execution and repairs of the work. CREDA, will, in no case be responsible for any accident fatal or non-fatal, caused to any workman or outsider in course of transport or execution or repairs of work.
- C.** All the expenditure including treatment or compensation will be entirely borne by the eligible SIs. The eligible SI shall also be responsible for any claims of the workers including, labour payments PF, Accidental Insurance, Gratuity, ESI & other legal obligations.
- D.** CREDA shall have all rights to deduct such claims of payments from SI in case of complaints of such violations.

22. NON-ASSIGNMENTS -

The eligible bidder shall not assign or transfer the Work Orders issued as per this contract or any part thereof without the prior approval of CREDA.

If eligible bidder transfer/assigned/sublet full or any part of work allocated to him without prior permission from CREDA in writing to any third party shall be liable to debar/black listed from any Bid/Activity of CREDA till further orders.

23. SUBLETS -

- A.** The eligible bidder may sublet / sub contract part of the work with approval of CREDA in writing up to 25% of the allocated work. It is expressly agreed that original bidder shall be responsible and liable for all his obligations under this agreement not withstanding anything contained in the agreements with his sub contractor and no default under any such agreement shall exempt the original bidder from his obligation or all liabilities here under.
- B.** After approval of the proposal of the sub contract CREDA shall issue a permission letter for the same.
- C.** The original bidder shall not be allowed to sub contract the work assigned to him to more than one sub contractor. In special condition CREDA may permit more than one sub contractor.
- D.** The original bidder should satisfy himself before recommending CREDA whether the sub contractor so proposed is fit for the work, process, experience, qualifications, man power and component necessary for the job proposed be entrusted to him.
- E.** Whatever warranty mentioned in the Bid document shall be honoured by the original bidder. Original Bidder shall be held responsible for any defect / non functionality of any work / system or any components.
- F.** CREDA will not ask to sub contractor for any rectification / replacement of work / system or any component. All liabilities regarding warranty shall be on part of original bidder.
- G.** The original bidder shall be responsible of submission of JCCs to concerned district officers of CREDA with his and sub contractor signatures and seal on every document comprising JCCs. The seal of sub contractor should clearly the name of sub contractor with phrase "on behalf of original bidder". All liabilities like warranty, insurance, specification, compliance of bid conditions and government rules and regulations etc.,

shall be on the part of original bidder.

- H.** Sub contractor will have to be registered as SI in CREDA immediate after approval.
- I.** CREDA will pay to the original bidder after successful commissioning of the system.
- J.** The original bidder shall have to make payments to the sub contractor within 15 days of receipt of payment from CREDA. CREDA may pay directly to the sub contractor on-behalf of original contractor after receipt of written consent / recommendation for payment from original bidder.
- K.** If original bidder fails to pay any amount to sub contractor within 45 days then on receipt of information from sub contractor CREDA shall have right to deduct the same from bill or any due amount of original bidders and pay the same to sub contractor.
- L.** The allocated work to sub contractor shall be part of the experience of sub contractor.
- M.** Details of the Subletting are mentioned in manual on policy and procedure for sub contract in CREDA. Already uploaded in CREDA's Website

24. CERTIFICATES NOT TO AFFECT RIGHTS OF CREDA -

The issuance of any certificate by CREDA or any extension of time granted by CREDA shall not prejudice the rights of CREDA in terms of the contract nor shall they relieve the eligible SI of his obligations for due performance of the contract.

25. SETTLEMENT OF DISPUTES THROUGH ARBITRATION -

- A.** Except as otherwise specifically provided in the contract, all disputes concerning questions of fact arising under the contract shall be decided by the Chief Executive Officer (CEO), CREDA provided a written appeal by the eligible SI is made to CREDA. The decision of the CEO, CREDA shall be final and binding to the all concerns.
- B.** Any dispute or difference including those considered as such by only of the parties arising out of or in connection with the contract shall be to the extent possible be settled amicably between the parties. If amicable settlement cannot be reached then all disputed issues shall be settled by arbitration.

26. LAWS GOVERNING CONTRACT -

The contract shall be constituted according to and subject to the Laws of India and jurisdiction of the High Court of Bilaspur, Chhattisgarh.

27. LANGUAGE AND MEASURES -

All documents pertaining to the Contract including specifications, schedules, notice correspondences, operating and maintenance instructions, drawings or any other writings shall be written in English / Hindi language. The metric system of measurement shall be used in this contract.

28. CORRESPONDENCE -

- A.** Any notice to the eligible SI under the terms of the contract shall be served by registered mail to the registered office of the eligible SI or by hand to the authorized local representative of the eligible SI and copy by post to the eligible SI's principal place of business.
- B.** Any notice to CREDA shall be served to the Chief Engineer, CREDA Raipur in the same manner.

29. SECRECY -

The eligible SI shall treat the details of the specifications and other documents as private and confidential and they shall not be reproduced without written authorization from CREDA.

30. AGREEMENT -

The successful eligible SI shall have to enter into an agreement with the CREDA in the approved contract agreement form within **10 days** of the receipt of call from CREDA.

- 31. DECLARATION OF CONFLICT OF INTEREST -** The contractor hereby declares that nobody connected with or in the employment of **CREDA** is not/shall not ever be admitted as partner in the contract.

32. BID EVALUATION CRITERIA -

- A.** Offers of only those parties, who are found qualified based on Eligibility Criteria and Techno-commercial Bid, will be taken into further consideration and financial bid of only those parties who are qualifying the criteria of Techno-commercial Bid will be opened.
- B.** Other things being equal, the lowest rates shall normally be preferred, but CREDA shall have rights and liberty to amend/lower the rates.
- C. Conditional Bids shall not be accepted.**
- D.** However CREDA shall have rights and liberty to call any /other parties to work on approved rates as and when requires in accordance with quantum of work and scheduled time limits for completion of targets.

33. EVALUTION OF PRICE BID -

Price bid shall be evaluated on the basis of Quoted rates. Lowest rates of each category of SPVPP shall be considered however CREDA shall have discretionary power to amend/lower the rates.

34. ALLOCATION OF TARGETS AND AREA OF WORK -

- i.** L-1 Bidder will be given preference for allocation of work.
- ii.** Subsequently all other eligible bidders will be awarded with equal number of work; quantity may change according to number of sanctioned works. Further allocations shall be made on the basis of their performance (both past as well as present performance) subsequently. However CREDA has sole discretion to award any number of works to any eligible bidder.
- iii.** CREDA reserve rights to increase or decrease quantities to be allocated to the eligible bidders on the basis of the availability of stock with the bidder and time limits for the projects.
- iv.** CREDA has full discretion to allot the work to any eligible bidder anywhere in the State of Chhattisgarh.
- v.** Maximum 10% of the total target shall be distributed among start-up and New Entrepreneur.
- vi. Review of the progress of installation of SPVPP System allocated to SIs shall be done time to time by CREDA and if the progress of installation is found unsatisfactory, the allocation of entire remaining uninstalled System or their part of can be re-allocated to other SI as per discretion of CREDA.**

35. BID REJECTION -

If financial bid of a bidder has been opened on the basis of technical bid of a bidder which has been determined to be substantially responsive to the bidding document and in latter stage it is found that bidder does not meet the eligibility criteria or the technical bid is found substantially non-responsive, CREDA reserves rights to reject such bid of a bidder any time.

We (on behalf of Eligible SI/Bidder) have read all the above stated details & accept to comply with it in total

(Name, Signature & Seal of the SI)

SECTION-3

SCOPE OF WORK

The scope of work in brief will be as follows-

1. Survey of Sites, design, supply, installation & commissioning of SPVPP as per design and specifications approved by CREDA and MNRE, on turnkey basis. Bidder shall have to take approval of the engineering documents, Bill of Materials and samples from CREDA prior to commencement of the work. Five years unconditional onsite warrantee for manufacturing defects shall be required for each of the system after successful commissioning and proper handing over.
2. The scope of work shall also include the following:
 - 2.1 Survey of Sites, Submission of site clearance certificate and layout where the SPVPP is to be installed. A layout plan of the site should also be submitted clearly indicating the identified location for installation of SPV power plant.
 - 2.2 Work order shall be issued only after receipt of satisfactory site clearance reports suitable for system installation.
 - 2.3 SI shall furnish all necessary information to beneficiary for SPV power plant Warrantee, DOs & Don'ts etc. so as to avoid further misunderstandings and disputes.
 - 2.4 Detailed planning of time bound smooth execution of project.
 - 2.5 Design, supply, installation & commissioning of SPV power plants of required capacity as per design and specifications approved by CREDA, on turnkey basis.
 - 2.6 Providing User Manuals and Warrantee Cards to beneficiary / CREDA.
 - 2.7 SI shall have to submit JCCs within 60 days of Installation and Commissioning of SPV power plant in District Office of CREDA.
 - 2.8 Unconditional onsite warrantee for manufacturing defects for Five years faultless operation, assure inventory for maintenance.
 - 2.9 Providing Prompt Service Facilities to customers/ beneficiaries.
 - 2.10 SI must ensure safety and insurance against risk liability of all personnel associated during installation and repairs of the system.
 - 2.11 Training of at least two persons nominated by user, on the various aspects of operation and maintenance of the offered system after commissioning of the system.
 - 2.12 The eligible SI shall maintain sufficient inventory of the spares to ensure that the system can be made functional within 7 days from the communication of breakdown of the system during the warrantee period.
 - 2.13 The eligible SI shall run the system on trial basis and shall closely monitor the performance of the system before handing over the system, so that the assured generation can be estimated for monitoring of the performance of the system. CREDA shall examine the generation and ascertain if the generation is adequate with reference to the capacity of the SPV power plant.
 - 2.14 The eligible SI shall have to monitor the performance of the system before its handing over to the beneficiary, so that the desired generation can be assured.
 - 2.15 Performance Guarantee Test: Successful performance guarantee test to demonstrate the rated capacity of SPV power plant as per CREDA's norms shall have to be conducted by SI in presence of representatives of CREDA, if required.
 - 2.16 System Integrators shall have to establish their service stations in the allocated area and shall have to keep sufficient quantity of spares and man power to ensure proper service network for taking care of smooth functioning of SPV power plant installed by them. SI shall have to give a toll free number to register complaints.
 - 2.20 Provision for RMS / Data Logger is necessary.
 - 2.21 The system shall have to be installed by trained manpower/contractor from a recognised training centre as per guidelines of CREDA. The training certificate can be checked by the officials of CREDA at the time of visit/inspection.
 - 2.22 A separate sign board must be affixed with proper clamping in the structure in a separate GI sheet of thickness 1.2mm. The matter for sign board must be approved by CREDA HO before installation.
3. LOI/Work Orders shall be issued only after ensuring following conditions-
 - 3.1 Bidder has submitted valid test report of the components, and survey report duly signed by concerned district office.
 - 3.2 During installation at the site bidder must make provision for Mixture machine & vibrator..

4. Successful Bidder / Bidder here-in-after called the **SI** (System Integrator):-
- i) After receipt of LOI from CREDA the eligible SI shall conduct a detailed survey of site and submit site details in prescribed format after due verification and signatures of AE/EE/Officer In Charge of CREDA. All necessary documents and survey details shall have to be submitted in concerned District Office of CREDA in prescribed manner. SI shall also have to submit site clearance, NOC for its use and a layout plan duly consented and signed jointly by him and AE/EE/Officer In Charge of CREDA.
 - ii) Engineer-in-Charge of District Office of CREDA shall examine these Survey report. After his satisfaction will forward details with his recommendations to EE of Concerned Regional Office of CREDA. Engineer-in-charge may visit the site if he/she is not satisfied with survey report.
 - iii) In case Engineer-in-Charge of District Office of CREDA finds the site not suitable for installation of SPVPP he/she will inform concerned beneficiary organisation / department accordingly and request for alternative site /necessary action.
 - iv) Executive Engineer of concerned Regional Office CREDA will decide the technical feasibility and layout plan of site. Executive Engineer may visit the site if he/she is not satisfied with survey report.
 - v) After satisfaction Executive Engineer will forward the site clearance report with technical feasibility to Head Office CREDA for issuance of work orders.
 - vi) HO CREDA will be final authority to approve or reject site finalisation recommended by Regional Offices.
 - vii) Concerned Chief Engineer of CREDA after his satisfaction shall issue the work order to eligible SI for installation of SPVPP.
 - viii) Work order will be given to the chosen System Integrator only after execution of the agreement with CREDA.
 - ix) After issuance of Work Orders Executive Engineer of concerned Regional Office CREDA will finally approve site layout in writing in prescribed format.
 - x) The SI shall start work within **15 days** after the date of approval of site layout.
- 4.4 All the materials required for the installation of SPVPP as per Work Order issued shall be kept at site in the custody of the SI. CREDA shall not be responsible for any loss or damage of any material during the installation.
- 4.5 All the electrical works should be done as per various provisions of Indian Electricity Act. The persons engaged for carrying out electrical works should have a valid **B-class** license or above issued by licensing board of Chhattisgarh.
- 4.6 After installation joint inspection will be done in presence of beneficiary, SI and CREDA and after successful commissioning of SPVPP and its approval from CREDA a JCC will be signed and forwarded for payments as per guidelines and procedures of CREDA.

SECTION - 4

TECHNICAL SPECIFICATION FOR SOLAR PHOTOVOLTAIC POWER PLANT

GENERAL TECHNICAL SPECIFICATION:

A standalone solar photovoltaic power generator/plant proposed comprises of solar PV modules of given capacity, with battery bank, PCU with necessary control electronics, interconnecting wires / cables, module mounting structures, necessary grounding /earthing etc.

BROAD TECHNICAL PARAMETERS

Sl.No	Category	Solar PV module Array Capacity (Wp)	PCU Capacity with MPPT and DC to AC Inverter (VA)	Battery Bank Capacity /Configuration LMLA & Lithium Ferro phosphate (Lifepo4)	
				Voltage in V	Capacity in AH
1	A	600	750	24	120
2		1200	1500	48	120
3		2400	3000	48	240
4		3000	3750	48	400
5		3600	4500	48	360
6	B	4800	6000	48	240
7		6000	7500	96	300
8		7200	9000	96	360
9		9000	11250	120	600
10		10500	13125	120	600
11	C	12000	15000	120	480
12		15000	18750	240	400
13		18000	22500	240	360
14		21000	26250	240	400
15		24000	30000	240	480
16		30000	37500	240	600
17		36000	45000	240	720
18		48000	60000	240	960
19		51000	63750	240	800
20		60000	75000	240	1200
21		80000	100000	240	1200
22		102000	127500	240	1000
23		120000	150000	240	1200
24	120000	150000	240	2400	

A. MINIMAL TECHNICAL REQUIREMENTS/ STANDARDS:

1.SPV MODULES:

- i. Only indigenous modules of reputed brand (IEC/BIS Tested) shall only be used in the system. The wattage of each module should be at least 300 Wp of 72 cell and open circuit voltage of the PV modules under STC should be at least 42.0 Volts. The module efficiency should not be less than 15% and the fill factor should not be less than 0.70.
- ii. Crystalline high power/efficiency cells > 16% shall be used in the Solar Photovoltaic module.
- iii. PV module must be warranted for output wattage, which should not be less than 90% at the end of 12 years and 80% at the end of 25 years.
- v. The terminal box on the module shall be designed for long life out door operation in harsh environment should have a provision for opening for replacing the cable, if required.
- vi. The offered module shall be in accordance with the requirements of MNRE.
- vii. Latest edition of IEC 61215 edition II / IS 14286 for Crystalline and shall be certified by MNRE authorized test centre. The bidder shall submit appropriate test certificates.
- viii. PV modules must qualify to IEC 61730 Part 1- requirements for construction & Part 2 – requirements for testing, for safety qualification.
- ix. Protective devices against surges at the PV module shall be provided. Low voltage drop bypass diodes shall be provided and if required, blocking diode(s) may also be provided.
- x. The peak power point voltage and the peak power point current of any supplied module and/or any module string (series connected modules) shall not vary by more than 2 (two) per cent from the respective arithmetic means for all modules and/or for all module strings, as the case may be.

x. IDENTIFICATION AND TRACEABILITY

Each PV module must have sticker inside the module with the following information:

- i. Name of the manufacturer of PV Module
- ii. Month and year of the manufacture of module
- iii. Made in India
- iv. Unique Serial No and Model No of the module

(Following data maybe provided out site in such a way that it should not pull out during harsh environmental condition)

- i. Peak Wattage, I_m , V_m and FF for the module
- ii. CREDA logo

Test reports/ certificate from IEC/NABL accredited laboratory to be mandatorily enclosed for relevant IEC/equivalent BIS Standards. All Solar modules shall be strictly as per MNRE's ALMM list w.e.f. 31.03.2020

2. BATTERY

2.1 Battery Bank & Technical Specifications For Lifepo4 Battery:

The battery should Lithium Ferro phosphate (**Lifepo4**) having capacity motioned in the chart at standard conditions. The configuration of battery assembly should be as per requirement of capacity. The cell should be prismatic type having capacity not less than 40 Ah The other feature of the battery should be:

Sr No.	Description	Specification
1	Battery Configuration minimum cell	3.2V- 40 AH; LiFePO4
2	Working Temperature Range (both for charging & discharging)	20-60 Deg C
3	Storage Temperature Range	@ 0-25 Deg- 6 months
4	Cycle Life (Full charge to full discharge @ 25 deg C before capacity of battery falls below 75%)	more than 3000 Cycles
5	Battery Warranty	5 years
6	Capacity of Individual Cells	3.2V- 40 AH atleast
7	Type of Cell	Prismatic

The Lithium iron phosphate battery needs a very good “Battery Management Systems” BMS to ensure the proper charging and discharging of each cell of battery with temperature compensation. This battery also needs constant current and constant voltage charging methodology related to upper voltage limit of battery. BMS primary focus is therefore on the safety and the protection of the battery pack, to minimize the risk of sudden failure and to maximize the life cycle of the battery. The secondary function of the BMS is to perform battery diagnosis, such as state of charge (SOC) estimation, state of health (SOH) estimation and state of power (SOP) estimation. Hence a very good battery management system to be incorporated and got it tested with battery from MNRE/NABAL accredited lab as per IEC/BIS standard.

2.2 Battery Bank & Technical Specifications For LMLA Battery:

2 Volts Tubular Plate Cell in dry charged condition for SPV Power Plant along with arrangement for inter connection for these cell in parallel connection, deep discharge electrolyte, Volt meter, Level indicator, Porcelain/acid resistant ceramic vent plug, Petroleum.

Supply of 12 Volts Tubular Plate long life low antimony Tubular Positive Plates Cells as per detailed Technical Specifications with deep discharge electrolyte insulated terminal connectors micro-porous ceramic vent plug for anywhere in the state of Chhattisgarh.

BATTERY BANK: Capacity with 12V Cell ranging from -24V/120Ah, 48V/(120-240)Ah, 96V/(300-360)Ah, 120V/(480-600)Ah, 240V/(400-2400)Ah

The battery bank capacity shall be of **Capacity with 12V Cell ranging from -24V/120Ah, 48V/(120-240)Ah, 96V/(300-360)Ah, 120V/(480-600)Ah, 240V/(400-2400)Ah** as specified in the price schedule, tubular plate LMLA type. The general specifications shall be as under:

- (a) The battery bank shall consist of required number of deep-discharge electrochemical storage cells, suitably interconnected as required. Parallel connections of storage cells will be discouraged.

- (b) The cells shall be capable of deep discharge and frequent cycling with long maintenance intervals and high columbic efficiency. Automotive or car batteries shall not be accepted.
- (c) The nominal voltage and capacity of the storage bank shall be selected and specified by the supplier in the bid.
- (d) The self-discharge rate of the battery bank or individual cell shall not exceed four (4) percent per month.
- (e) The permitted maximum depth of discharge (DOD) shall be specified by the supplier in the bid.
- (f) Unless otherwise specified the cycle life of the battery shall not be less than 1200 DC discharged cycles between the fully charged state and the permitted maximum DOD at the rate of C/10. It should be able to deliver 80% of its rated capacity from fully charged position to DOD.
- (g) The cells shall include explosion proof safety events.
- (h) The cells shall include the required number or corrosion resistant inter-cell required chemicals electrolyte packed in separate containers. Full instructions and technical details shall be provided for electrolyte filling and battery recharging at site for the first time.
- (i) The cells shall preferably be supplied in dry charged condition, complete with all required chemicals electrolyte packed in separate containers. Full instructions and technical details shall be provided for electrolyte filling and battery recharging at site for the first time.
- (j) If the cells are supplied in uncharged conditions, then the supplier shall provide full instructions for first time charging including, but not limited to, the following:
 - A check list of all items required.
 - Minimum specification with possible alternatives, of the required battery charger for first time charging
 - Instruction of electrolyte filling, battery charging etc. and instructions on the transportation of charged batteries, if required.
- (k) Suitable number of corrosion resistant and acid-proof storage racks shall be supplied to accommodate the cells. The rack design shall be such that minimum space is required, without any way obstructing the maintenance requirements. For metallic racks, standards specified for control panel enclosures and other metallic shall govern.
- (l) All technical and other details pertaining to the storage cells shall be supplied including but not limited to the following: -

Rated voltage and ampere hour capacity of each storage cell has the rated discharge rate.

 1. Permitted maximum DOD.
 2. Self discharge rate.
 3. Cycle life of the storage cell and the anticipated life (in years) of the battery bank.
 4. Total number of storage cells in use.

5. Details on cell interconnections, if any.
6. Rates for single tier and double tier battery rate should be quoted in Price Bid.
7. Self discharge per month < 3% @ 27°C.
8. Charge efficiency >93% @ 20% DOD (i.e. 80% SOC).
9. Topping-up frequency not more than once in 12 months after commissioning.
10. Supplied in dry charge condition.
11. Insulated terminal connectors, fasteners, sealed floats and charge instruction card supplied.
12. Special micro-porous ceramic vent plugs.
13. Low antimony tubular positive plates.
14. Rugged construction & Long Cycle life.

Battery Rack For LMLA Battery:

Battery rack for the battery bank of 2V cells should be of Metallic suitable for battery mounting & duly painted. Placement of battery should be such that maintenance of the battery could be carried out easily. The non-reactive acid proof mat should be provided to cover the entire floor space of the battery room.

3. POWER CONDITIONING UNIT (PCU) CUM INVERTER

The Power conditioning unit (PCU) should have inbuilt charge controller and Inverter of capacity & ratings as specified in the Table for various capacity of Solar Power Plants

The PCU will have following features:

- i. MOSFET/ IGBT based MPPT charging.
- ii. Output voltage 230V+2% of modified/ pure sine wave for single phase PCU & 415 V +2%.for three phase PCU.
- ii. Output frequency: 50 Hz+0.5 Hz
- iii. Capacity of PCU/ Inverter is specified at 0.8 lagging power factor.
- iv. THD: less than 3%
- v. Efficiency: >90% of PCU at full load
- vi. Indicator:
 - Array charger on
 - Battery charging
 - Inverter ON
 - Load on solar/ battery
 - Grid charger on
 - Load on Grid
 - Grid on
 - Fault
- Vii. Display parameters
 - Charging current
 - Charging voltage
 - Voltage of PV panels
 - Output voltage
 - Grid voltage
 - Power output in KW
 - Energy delivered in Kwh

- Viii. MIMIC Diagram: To indicate power flow and operation of the charge controller/ battery charger; shall have provision for visual indications of existing power input/output through MIMIC diagram .
- ix . The PCU should be dual input type, where under normal condition the input is fed from a SPV panel and in the absence of SPV power or low SPV power conditions an external AC source can be used for battery charging. All these operation should be automatic. When battery bank is fully charged, the PCU should have the feature to feed the power generated from solar to load and draw the additional power from main supply to meet the load requirements in the case load is more than solar energy produced. The PCU continuously monitors the state of Battery Voltage, Solar Power output and the loads. Due to sustained usage of power, when the Battery Voltage falls below a preset level, the PCU will automatically transfer the load to the grid power and also charge the Batteries through the inbuilt Grid Charger. Once the batteries are charged to the present level, the PCU cuts off the Grid power from the system and will restore to feeding the loads from the battery bank & continue to charge the battery bank from the available solar power. The PCU always gives preference to the solar power and will use Grid power only when the solar power / battery charge is insufficient to meet the load requirement.
- Full Protection against polarity reversal of PV array and battery, Over Current, Short Circuit, Deep Discharge, Input Surge Voltage , open circuit, accidental short circuit and night time leakage of current from battery to module.
 - Adequate protection shall also be incorporated under no-load conditions (i.e. when the system is ON & the load is removed).
- The PCU charge controller must be synchronize with Battery Management System (BMS).

The PCU/ inverters should be tested from the MNRE / NABL /BIS /IEC accredited testing calibration laboratories.

B. BALANCE OF SYSTEM (BOS) ITEMS/ COMPONENTS:

The BOS items / components of the SPV power plants/ systems deployed must conform to the latest edition of IEC/ Equivalent BIS Standards/ MNRE specifications / as specified below:

S NO	BOS ITEMS/SYSTEMS	Applicable BIS/Equivalent IEC Standard Or MNRE Specifications	
		Standard description	Standard no.
1	Charge Controller/ MPPT Units	Environment Testing	IEC 60068-2(1,2,14,30)/equivalent BIS standard
2	Power Conditioner/Inverters including MPPT and protection	Efficiency measurements	IEC 61683/IS 61683 and IS 16221
		Environment testing	IEC 60068-2(1,2,14,30)/equivalent BIS standard
3	Storage Batteries	General requirements & method of testing tublar lead acid /VRLA/GEL/ /maintenance free capacity test,charge/Discharge efficiency ,self discharge	IS 16046 (PART-2):2018/ ICE 62133-2:2017
4	Cables	General test and measuring method PVC insulated cables for working voltage up to and including 1100V and UV resistant for outdoor installation	IEC 60227/IS 694 IEC 60502/IS 1554(Part I & II)
5	Switches/Circuits/Breakers/connectors	General requirements connectors –safety AC/DC	IEC 60947 part I,II,III/IS 60947 PART I,II,III/EN 50521
6	Junction boxes/enclosures for inverters/charge	General requirements	IP 54(for outdoor)/IP21 9for indoor) as per IEC 529

**In case if the Charge controller is in-built in the inverter, no separate IEC 62093 test is required and must additionally conform to the relevant national/international Electrical Safety Standards wherever applicable.

4.MOUNTING STRUCTURE

- I.The module & frame structure shall be mild steel, hot dipped galvanized (80 micron) with corrosion resistant painting for holding the PV modules.
- II.Each panel frame structure shall be so fabricated as to be grouted on ground on its legs.
- III.The size of angle iron/C channel should not be less than 40X40X5 mm. Anti-Theft Nut Bolts of SS (with washers) should be used for mounting modules for better theft proofing. Regarding civil structures. The bidder need to take care of the load baring capacity of the roof and need to arrange suitable structures based on the quality of roof.
- IV.The total load of the structure (when installed with PV modules) on the terrace should be less than 60 kg/m²
- V.The minimum front clearance of the structure from the roof level should be 300 mm.
- VI.The legs of the structures made with hot dip GI angles will be fixed and grouted in the RCC foundation columns made with 1:2:4 cement concrete. The foundation should be as per design of structure to withstand maximum wind loading.
- VII.There shall be a minimum air gap of 3+/- 0.3-cm between the facing edges of two adjacent modules on all sides.

- VIII. Each panel frame structure shall have inclination between 20- 40 degrees depending on the site location seasonal load requirement. A weather proof junction box as per the relevant ISI specifications, to be provided where the module terminals shall be interconnected and output taken.
- IX. All nuts bolts, and fasteners should be made of stainless steel.
- X. The structure should be designed to allow easy replacement of any module and shall be aligned with site requirement.
- XI. The structure should be designed for simple mechanical and electrical installations.
- XII. It will be designed to withstand severe cyclone/ storm with the speed max.150 Km/hr (STAD report may be required to be submitted)
- XIII. The systems should be installed at ground level / roof top at least the height of 450mm with a CC block of 300X300X300 mm with each support.

5. BATTERY TROLLEY/RACK

A metallic box of minimum 18 SWG thick made of pre coated galvanized (60 micron thickness) ms sheet or Polymer/ABS box of minimum 2 mm thickness for housing the storage battery indoors should be provided with proper lock and key. The boxes should be inscribed with CREDA written on front faces. The size of box should be as per battery size. The battery should be fixed inside the battery box so it should be properly separated to avoid the electrical contact between battery and box. Danger logo as approved by CREDA shall be screen printed on the box.. The BMS module is the part of battery pack.

6. ELECTRICAL CONNECTIONS

High quality ISI mark copper wires/cables of reputed makes are to be provided for connecting Solar Modules, from junction box to PCU, and Battery.

A suitable connection point shall be provided to the consumer from PCU, at a distance not more than 05 meters, from where consumer shall have its own wiring to the use points.

7. JUNCTION BOXES:

The junction boxes for 5KW and above are to be provided in the PV array for termination of connecting cables. The J. Boxes (JBs) shall be made of GRP/FRP/Powder Coated Aluminium /cast aluminium alloy with full dust, water & verminproof arrangement. All wires/cables must be terminated through cable lugs. The JB's shall be such that input & output termination can be made through suitable cable glands.

Copper bus bars/terminal blocks housed in the junction box with suitable termination threads conforming to IP65 standard and IEC 62208 Hinged door with EPDM rubber gasket to prevent water entry. Each Junction Box shall have High quality Suitable capacity Metal Oxide Varistors (MOVs) / SPDs, suitable Reverse Blocking Diodes. The Junction Boxes shall have suitable arrangement monitoring and disconnection for each of the groups. Suitable markings shall be provided on the bus bar for easy identification and the cable ferrules must be fitted at the cable termination points for identification. For System 5Kw below normal junction boxes with necessary fixture should be used. DC DPBs shall have sheet from enclosure of dust & vermin proof conform to IP 65 protection. The bus bars are made of copper of desired size. Suitable capacity MCBs/MCCB shall be provided for controlling the DC power output to the PCU along with necessary surge arrestors AC Distribution Panel Board (DPB) shall control the AC power from PCU/ inverter, and should have necessary surge arrestors. Interconnection from ACDB to consumer main power board.

All switches and the circuit breakers, connectors should conform to IEC 60947, part I, II and III/IS60947 part I, II and III. The changeover switches, cabling work should be undertaken by the bidder as part of the project. All the Panels shall be metal clad, totally enclosed, rigid, floor mounted, air insulated, cubical type suitable for operation on three phase / single phase. The panels shall be designed for minimum expected ambient temperature of 55 degree Celsius, 80 percent humidity and dusty weather. All indoor panels will have protection of IP54 or better. All outdoor panels will have protection of IP65 or better should conform to Indian Electricity Act and rules (till last amendment). Connecting cables PVC insulated copper cables (ISI marked) for: The cable should be used as per site considering the maximum permissible loss up to 2%, however for 5 KW plant the minimum cable should be as follow:-

Module interconnections (4.0 mm copper single core multi strand),

Module parallel interconnection (10 mm copper single core multi strand)

Array or AJB to PCU (16 mm copper two cores)

Battery to PCU (16 mm copper single core multi strand) might be double cables if required PCU to load / change over switch (Single core copper cable 6.0 mm multi strand) as per requirement of site.

8. LIGHTNING AND OVER VOLTAGE PROTECTION:

The SPV Power Plant shall be provided with lightning and over voltage protection. The principal aim in this protection is to reduce the over voltage to a tolerable value before it reaches the PV or other sub-systems components. The source of over voltage can be lightning or any other atmospheric disturbance. The Lightning Arrestor (LA) is to be made of 1¼" diameter (minimum) and 12 feet long GI spike on the basis of the necessary meteorological data of the location of the projects. Necessary foundation for holding the LA is to be arranged keeping in view the wind speed of the site and flexibility in maintenance in future. Each LA shall have to be earthed through suitable size earth bus with earth pits. The earthing pit shall have to be made as per IS 3043. LA shall be installed to protect the array field, all machines and control panels installed in the control rooms. Number of LA shall vary with the capacity of SPV Power Plant & location.

9. **Surge Protection Device:** Internal surge protection shall consist of three MOV type arrestors connected from +ve and -ve terminals to earth (via Y arrangement) for higher withstand of the continuous PV-DC voltage during earth fault condition. SPD shall have safe disconnection and short circuit interruption arrangements through integrated DC in built bypass fuse(parallel) which should get tripped during failure mode of MOV, extinguishing DC arc safely in order to protect the installation against fire hazards. Nominal discharge current (In) at 8/20 micro seconds shall be minimum 10 KA with maximum discharge (I_{max}) at 8/20 micro seconds minimum 20 KA with visual indication (through mechanical flag) in modules to monitor the life of SPD.

10. EARTHING PROTECTION:

Each array structure of the PV yard shall be grounded properly. In addition the lightning arrester/masts shall also be provided inside the array field. Provision shall be kept for shorting and grounding of the PV array at the time of maintenance work. All metal casing/shielding of the plant shall be thoroughly grounded in accordance with Indian Electricity Act/IE rules as amended up to date. The earthing pit shall be made as per IS: 3043. All the array structures, equipments & control systems shall be compulsorily connected to the earth. Number of earthing shall vary with the capacity of SPV Power Plant & location. G.I. /Copper strips should be used for earthing instead of G.I. wires. LA should be installed to protect the array field & machines installed in the control rooms. Number of LA shall vary with the capacity of SPV Power Plant & location. The LA installations should be get approved from CREDA prior to installation.

11. DC DISTRIBUTION BOARD (DCDB):

This shall consist of suitable powder coated metal casing. In this box a separate arrangement which shall consist of MCCBs of suitable specifications & which can withstand respective flow of current, with the purpose of providing the option for isolating the battery bank & SPV arrays should be made. There shall be copper bus bars of suitable rating. Proper rating HRC fuse & MCCB/Isolator for DC application should be suitably installed in DCDB as battery bank isolator. Best quality Ah meter has to be installed to measure the cumulative charging & discharging status of battery bank. In DC circuits AC MCB or MCCB shall not be permitted. As per drawing attached. Volt meter/ Amp meter to measure charging and discharging current/ voltage.

12. AC DISTRIBUTION BOARD (ACDB):

This shall consist of box of suitable powder coated metal casing. One feeder per phase shall be provided in ACDB with MCB of suitable capacity installed at each feeder in the ACDB. One Electronic Energy Meter, ISI make, Single / Three Phase, of good quality shall also be installed in ACDB suitable placed to measure the consumption of power from SPV Power Plant. Proper rating MCB shall be installed at every feeder (in case of single phase output also, there shall be three feeders) to protect feeders from the short circuit current as per the requirement of the site & instructions of CREDA. A separate dedicated feeder from conventional/grid line to PCU as well as ACDB should also be installed, if required as per CREDA's instruction. A separate change over switch of proper rating should also be suitably installed in the ACDB to isolate the existing connected load from the Solar System & cater the power to the existing load from conventional power (Grid), in case of emergency. ACDB should be connected between PCU & Load. Separate Electronic Energy Meters should be installed for incoming and outgoing circuits of ACDB for SPVPPs of capacity more than 1 kWp. Two nos. of Timer for suitable capacity with connector and SPD of suitable Capacity for Lightning protection shall be installed.

13. DANGER BOARDS:

Danger boards should be provided as and where necessary as per IE Act/IE Rules as amended up to date as per the instructions of CREDA & affixed at various appropriate locations.

14. CABLES/WIRE:

All cables should be of copper as per IS and should be of 650V/1.1 KV grade as per requirement. All connections should be properly made through suitable lug/terminal crimped with use of suitable proper cable glands. The size of cables/wires should be designed considering the line losses, maximum load on line, keeping voltage drop within permissible limit and other related factors. The cable/wire should be of ISI/ISO mark for overhead distribution, with prior approval of CREDA. For normal configuration the minimum suggested sizes of cables are:

Module to module/SJB/AJB	-	4 sq mm (single core)
AJBs to MJBs/DCDB	-	16 sq mm (two core), with respect to current ratings of designing
MJBs to DCDB	-	minimum 50 sq mm (single core) or as per design & rating
DCDB to PCU	-	minimum 50 sq mm (single core), or as per design & rating
Battery to BPP	-	minimum 50 sq mm (single core) or as per design & rating
BPP to DCDB	-	minimum 50 sq mm (single core) or as per design & rating
DCDB to PCU	-	minimum 50 sq mm (single core) or as per design & rating
PCU to ACDB	-	as per design & rating

The size & rating of the cables may vary depending on the design & capacity of SPV Power Plant. Follow the attached drawing. Tenderer should compulsorily get the design & rating of the cables approved from CREDA prior to the installation. Tenderer has to provide certificate cable used in SPVPP.

15. **JUNCTION BOXES:** Junction Boxes (SJB / AJB / MJB) shall be mounted on poles of array support structure. The junction boxes should be made of FRP (Hensel or equivalent make (IP65), with prior approval of CREDA). It should be provided with proper locking arrangements.

16. **Tool Kit:** Complete tool kit other than battery tool kit with tool box for complete maintenance and operation including spanner, screw driver, wire cutter, nose pliers, pliers, hammer etc.

17. DATA ACQUISITION SYSTEM / PLANT MONITORING

- A.** Data Acquisition System shall be provided for each of the solar PV plant having capacity 10 KW or above.
- B.** Data Logging Provision for plant control and monitoring, time and date stamped system data logs for analysis. Metering and Instrumentation for display of systems parameters and status indication to be provided.
- C.** Solar Irradiance: An integrating Pyrometer / Solar cell based irradiation sensor (along with calibration certificate) provided, with the sensor mounted in the plane of the array. Readout integrated with data logging system.
- D.** Temperature: Temperature probes for recording the Solar panel temperature and/or ambient temperature to be provided complete with readouts integrated with the data logging system
- E.** The following parameters are accessible via the operating interface display in real time separately for solar power plant:
- a. AC Voltage.
 - b. AC Output current.
 - c. Output Power
 - d. Power factor.
 - e. DC Input Voltage.
 - f. DC Input Current.
 - g. Time Active.
 - h. Time disabled.
 - i. Time Idle.
 - j. Power produced

18. OTHER FEATURES

A toll free number (i.e. 1800 12345 91) of IVRS of CREDA and CONTACT NUMBER OF TECHNICAL PERSON INSTALLATION AGENCY of minimum computer font size 72 or 13 mm is to be embossed/ punch in front of battery box by contractor/ bidder, which in case of non-working/operational problems etc of system will be dialed by the beneficiary etc to lodge a complaint in respect of system problems. The IVRS will divert the complaint to Contractor/ bidder through E mail, SMS etc. The contractor/ bidder will have to rectify the same to make/ restore the system to working position within 72 hours in the warrantee period of 5 years, failing which the system may be get rectified on contractor/ bidder cost and the cost will be recovered by contractor/ bidders pending claims what so ever and appropriate action as per noncompliance etc of agreement will be considered/taken.

19. INSTALLATION OF SYSTEM:

The system should be properly installed at site. The SPV module mounting structure should be properly grouted depending upon the location and requirement of the site. The grouting should be such that it should withstand the maximum wind speed /storm. Adequate space should be provided behind the PV module/array for allowing un-obstructed air flow for passive cooling.

Cables of appropriate size should be used to keep electrical losses to a bare minimum. Care should be taken to ensure that the battery is placed with appropriate levelling on a structurally

sound surface. All wiring should be in a proper conduit or capping case. Wire should not be hanging loose. Any minor items which are not specifically included in the scope of supply but required for proper installation and efficient operation of the Solar Power Generator/Plant system, is to be provided by the manufacturer as per standards.

20. ELECTRIC CABLE

All the cables shall be supplied conforming to IEC 60227– IS 694 / IS 1554 – IS / IEC 60502 shall be of 650 V/1.1 kV grade as per requirement. Only PVC copper cables shall be used.

21. WARRANTY

The mechanical structures, electrical works including power conditioners/inverters/charge controllers/ maximum power point tracker units/distribution boards/digital meters/ switchgear/ storage batteries, etc. and overall workmanship of the SPV power generator/Plant system must be warranted against any manufacturing/ design/ installation defects for a minimum period of 5 years.

22. TRACEABILITY OF THE PRODUCT TO BE SUPPLIED

In order to prevent the misuse of the product such as unauthorized sale or diversion to the open market, the following incorporation shall be made in the product.

A. Engraving (or) Screen printing of CREDA at a suitable place on the main components viz SPV Panel, battery, PCU to be used in the installation of the solar power pack.

23. SPECIFICATIONS OF ELEVATED STRUCTURES

1. Specification of Elevated Parking Structure with Control Box for 1.2 KW SPVPP

- Steel Should be used – IS2062 Grade-A
- All Weld Must be 6mm
- All Fabrication should be completed before hot dip galvanized
- Hot Dip Galvanizing should be as per Relevant IS
- Specification and Zinc Coating 87 Microns/610 gm Per Sq.m.

2. Specification of Elevated Parking Structure with Control Room for 2.4 KW SPVPP

- Steel Should be used – IS2062 Grade-A
- All Weld Must be 6mm
- All Fabrication should be completed before hot dip galvanized
- Hot Dip Galvanizing should be as per Relevant IS
- Specification and Zinc Coating 87 Microns/610 gm Per Sq.m.

3. Specification of Elevated Parking Structure with Control Room for 3.0 KW SPVPP

- Steel Should be used – IS2062 Grade-A
- All Weld Must be 6mm
- All Fabrication should be completed before hot dip galvanized
- Hot Dip Galvanizing should be as per Relevant IS
- Specification and Zinc Coating 87 Microns/610 gm Per Sq.m.

4. Specification of Elevated Parking Structure with Control Room for 4.8 KW SPVPP

- Steel Should be used – IS2062 Grade-A
- All Weld Must be 6mm
- All Fabrication should be completed before hot dip galvanized
 - Hot Dip Galvanizing should be as per Relevant IS
 - Specification and Zinc Coating 87 Microns/610 gm Per Sq.m.

5. Specification of Elevated Parking Structure with Control Room for 6.0 KW SPVPP

- Steel Should be used – IS2062 Grade-A
- All Weld Must be 6mm
- All Fabrication should be completed before hot dip galvanized
- Hot Dip Galvanizing should be as per Relevant IS
- Specification and Zinc Coating 87 Microns/610 gm Per Sq.m.

6. Specification of Elevated Parking Structure with Control Room for 9.0 KW SPVPP

- Steel Should be used – IS2062 Grade -A
- All Weld Must be 6mm
- All Fabrication should be completed before hot dip galvanized
- Hot Dip Galvanizing should be as per Relevant IS
- Specification and Zinc Coating 87 Microns/610 gm Per Sq.m.

7. Specification of Elevated Parking Structure with Control Room for 10.5 KW SPVPP

- Steel Should be used – IS2062 Grade -A
 - All Weld Must be 6mm
 - All Fabrication should be completed before hot dip galvanized
 - Hot Dip Galvanizing should be as per Relevant IS
 - Specification and Zinc Coating 87 Microns/610 gm Per Sq.m.
-

24 .WARRANTY AND MAINTENANCE

1. The PV modules will be warranted for a minimum period of 25 years from the date of supply. (Output wattage should not be less than 90% at the end of 12 Years and 80% at the end of 25 years).
2. The mechanical structures, electrical components including battery and overall workmanship of the complete Solar PV Power Pack must be warranted against any manufacturing/ design/ installation defects must be warranted for a minimum of 5 years from the date of commissioning and handing over of the system.
3. The Comprehensive Maintenance (within warranty period) shall be executed by the firm themselves or through the authorized dealer/ service centre of the firm in the concerned district. Separate work order shall be issued by CREDA for the COMC.
4. It is mandatory for the contractor to open an authorized service center in the concerned area before the supply/ installation of the system.
5. Necessary maintenance spares for five years trouble free operation shall also be supplied with the system.
6. The supplier shall be responsible to replace free of cost (including transportation and insurance expenses) to the purchaser whole or any part of supply which under normal and proper use become dysfunctional within one month of issue of any such complaint by the purchaser.
7. The Comprehensive Maintenance (within warranty period) will include the total system including Battery etc whatsoever at site.
8. It is an essential part of the contract that the bidder shall provide warranty of the system for 5 years. During the warranty following maintenance will required to be carried out by the contractor.
9. Quarterly checking up keeping and replacement of the any component or subcomponents of the system for proper operation of the system.
10. Repairing/replacement of all defective components and sub-components including battery of the system as per the requirement to ensure proper operation of the system.
11. The scope of work includes repairing/replacement of power plant to make the system functional within warranty period whenever a complaint is lodged by the user at site. The contractor shall attend the same within a week. Apart from this any complaint registered/ service calls received / faults notified in the report generated by the IVRS should be attended to and the system should be repaired/ restored/ replaced within 4 days.
12. In case of any damage or breakage of the component due to negligence or fault of beneficiary or theft etc, the same shall be replaced at users cost.
13. In case of Solar PV module damaged due to natural calamity, contractor shall replace the same at his own cost, if required during warranty period.
14. The safety and security of the system shall be sole responsibility of the user.

e-tender No: CREDA-2019

25 Technical BID

S.no	Description	To be furnished by the Contractor/Bidder
A.	Solar PV Module	
1.	Type of Module: Crystalline/multicrystalline	
2.	Manufacturer	
3.	Max power at STC Pmax (W)	
4.	Voltage at Max power Vmp(V)	
5.	Current at Max power Imp(A)	
6.	Open circuit voltage Voc (V)	
7.	Short circuit current Isc (A)	
8.	Module efficiency	
9.	Rated capacity of SPV panels at STC	
10.	Fill factor	
B.	Battery	
1.	Manufacturer	
2.	Type	
3.	Capacity of Battery at C10	
4.	Max DOD	
5.	Charge efficiency	
C	Battery Rack/Trolley	
1	Manufacturer	
2	Material	
D	AC Hybrid Solar Power Conditioning Unit	
1.	Manufacturer :	
2.	Operating voltage (DC)	
3	Operating voltage AC (pure sine wave)	

Seal & Signature of Bidder

4	THD	
5.	Details of Indicators provided	
6.	Details of Protections provided	
	i. Battery Over charge set value	
	ii. Deep discharge set value	
	iii. Short Circuit	
	iv. Open Circuit	
	v. Reverse polarity	
	vi. Reverse current	
vii. Others		

Seal and Signature of Bidder

Important Note:-Bidder shall have to submit the technical details for each capacity of systems.. In case of the use of component of other make prior approval must be taken by CREDA before supply and installation of systems.

26.e-Price Bid

e-Price Bid (For supply, installation, Commissioning & Testing of spvpp)

Schedule of Rates for SPV power plant

(e-bidding as per Specifications & Scope of Work of No.13366/CREDA/HOR/RE-III/SPVPP2019 Dated :
06.11.2019)

Financial offer of Rate Contract for the Design, Supply, Installation, Commissioning, with 05 years warranty with comprehensive maintenance (in warrantee period including battery) of AC Hybrid Solar Power Generator/Plant as per scope of work, Tech. requirement, Specifications & terms and conditions etc of the tender.

Price Bid Part A

S no	Category	Details of solar power plant with Lifepo4 battery bank	Rate for supply of material for solar power plant including Module,battery,Hybrid Inverter ,Structure, PCU, Structure Earthing,LA and other complete BOS material Exe. GST(In.Rs)	Rate for complete installation and commissioning of solar power plant Ex.GST (In Rs.)	Total Price (In Rs.)Ex GST
		Module cap./Battery Bank Cap./Battery Bank Voltage	A	B	C=A+B
1	A	600W/120AH/24V			
2		1200W/120AH/48V			
3		2400W/240AH/48V			
4		3000W/400AH/48V			
5		3600W/360AH/48V			
6	B	4800W/240AH/48V			
7		6000W/300AH/96V			
8		7200W/360AH/96V			
9		9000W/ 600AH/ 120V			
10		10500W/ 600AH/ 120V			
11		12000W/480AH/120V			
12	C	15000W/400AH/240V			
13		18000W/360AH/240V			
14		21000W/400AH/240V			
15		24000W/480AH/240V			
16		30000W/600AH/240V			
17		36000W/720AH/240V			
18		48000W/960AH/240V			
19		51000W/800AH/240V			
20		60000W/1200AH/240V			
21		80000W/1200AH/240V			
22		102000W/1000AH/240V			
23		120000W/1200AH/240V			
24		120000W/2400AH/240V			

Price Bid Part A-1

S no	Category	Details of solar power plant with LMLA battery bank	Rate for supply of material for solar power plant including Module,battery,Hybrid Inverter ,Structure, PCU, Structure Earthing,LA and other complete BOS material Exe. GST(In.Rs)	Rate for complete installation and commissioning of solar power plant Ex.GST (In Rs.)	Total Price (In Rs.)Ex GST
		Module cap./Battery Bank Cap./Battery Bank Voltage	A	B	C=A+B
1	A	600W/120AH/24V			
2		1200W/120AH/48V			
3		2400W/240AH/48V			
4		3000W/400AH/48V			
5		3600W/360AH/48V			
6	B	4800W/240AH/48V			
7		6000W/300AH/96V			
8		7200W/360AH/96V			
9		9000W/ 600AH/ 120V			
10		10500W/ 600AH/ 120V			
11		12000W/480AH/120V			
12	C	15000W/400AH/240V			
13		18000W/360AH/240V			
14		21000W/400AH/240V			
15		24000W/480AH/240V			
16		30000W/600AH/240V			
17		36000W/720AH/240V			
18		48000W/960AH/240V			
19		51000W/800AH/240V			
20		60000W/1200AH/240V			
21		80000W/1200AH/240V			
22		102000W/1000AH/240V			
23		120000W/1200AH/240V			
24		120000W/2400AH/240V			

Price Bid -Part B

S.no	Details	Unit	Rate Excluding GST(In RS.)
1	Supply of hot dipped galvanised Module mounting structure (80Micron) for solar power plant with all accessories(must be able to Withstand 150 Km/hr)	Per KW	
2	Installation of hot dipped galvanised Module mounting structure (80Micron) for solar power plant with all civil material		
3	Supply of parking Shed type hot dipped galvanised Module mounting structure (80Micron) for solar power plant with all accessories(must be able to Withstand 150 Km/hr)	Per KW	
4	Installation of hot dipped galvanised Module mounting structure (80Micron) for solar power plant with all civil material		

Above rates are FOR anywhere in the State of Chhattisgarh inclusive of roadworthy packing, loading, unloading, all types of incidental expenses, 5 years warrantee, insurance and COM as mentioned in the Bid document. Above rates applicable for SPVPP models for each category as per MNRE and CREDA Specifications stated in Bid document (Page 28-38). **According to GST notification no. 24 /2018-Central Tax (Rate) Dated 31.12.2018 GST Rate will be applicable under composite supply and installation basis. Rate of GST on Supply of Goods (70% of gross consideration treated as supply of Goods) 5% GST and balance portion (30% of gross consideration treated as taxable installation services) 18% GST will be Paid extra as per prevailing rate. No other cost will be claimed other than above quotes price & the applicable GST.**

Note: In this regard if there is any change in the composition ratio of goods and services by any Authority/ Courts, same shall be applicable.

Signature of the Authorized Signatory :

Seal of Company :

.....
Date :

.....

27.DRAFT AGREEMENT

CONTRACT AGREEMENT BETWEEN Chief Engineer Chhattisgarh State Renewable Energy Development Agency (CREDA) Raipur AND M/s..... Represented by THIS CONTRACT AGREEMENT against Bid No.13366/CREDA/HOR/SPVPP/2019 Dated : 06.11.2019 (also referred to as “Service Contract”) is made on the ____ day of ____ 2019.

BETWEEN

(1) Chief Engineer Chhattisgarh State Renewable Energy Development Agency (CREDA) Raipur a society incorporated under the laws Society Registration Act 1973 , (1973 , Sr. No. 44) (with amendment from time to time) and having its Registered Office at VIP Road Near Energy Education Park, Village- Fundhar, Raipur and (hereinafter called “The Employer” and also referred to as “CREDA”)

And

(2) Represented bya company incorporated under the laws of Companies Act 1956/2013/ Partnership firm/ Proprietorship firm/Consortium (as applicable, with amendment from time to time) and having its Principal place of business at and Registered Office at.....hereinafter called “The Contractor” and also referred to as “.....”

Whereas the contractor has offered to enter into contract with the said CREDA for the design, survey ,supply, installation and commissioning of solar power plant with Lifepo4 battery bank and hybrid PCU ,capacity ranging from 600W to 100KW with 5 years onsite unconditional warranty anywhere in the state of Chhattisgarh vide Bid No.13366/CREDA/HOR/RE-III/SPVPP/2019 Dated : 06.11.2019 on the terms and conditions herein contained and the rates approved by the CREDA (Letter No. dated annexed here to) have been duly accepted and where as the necessary security deposit shall be furnished in accordance with the provisions of the Bid document and whereas no interest will be claimed on the security deposits.

Now these presents witness and it is hereby agreed and declared by and between parties to these presents as follows -

- 1) The Contractor shall, during the period of this contract, that is to say from to or completion thereof, until this Contract shall be determined by such notice as is hereinafter mentioned, safely carryout, by means of labours employed at his own expenses and by means of tools, implements and equipment etc. to be supplied by him to his labour at his own expenses, for installation of “Solar power plant” as described in Bid documents. (Annexed to the agreement).
- 2) The NIT (Notice Inviting Bid), Corrigendum to NIT, Notices, Bid documents (Qualifying, Technical and Financial), approved rates annexed hereto and such other additional particulars, undertaking, instructions, general conditions of contract, Scope of work, Technical specifications of Solar SPVPP Systems and Annexure therein, engineering documents, detailed specifications of BOS & drawings, so far they relate to the Bid No.13366/CREDA/HOR/SPVPP/2019 Dated : 06.11.2019 as may be found requisite to be given during execution of the work shall be deemed and taken to be an integral part of the contract and shall also be deemed to be included in the expression "The Agreement or "The Contract "wherever herein used.
- 3) The contractor shall also supply the requisite number of workmen with means & materials as well as tools, appliances, machines, implements, vehicles for transportation, cartage etc. required for the proper execution of work within the time prescribed in the work orders and /or as per the Bid conditions.

- 4) The Engineer in Charge or his authorized representative (s) shall be entitled at all reasonable times to inspect and supervise and test during installation and commissioning. Such inspection will not relieve the eligible SI from their obligations under this contract.
- 5) Material can be inspected before dispatch or in transit by the authorized representatives of CREDA at the factory at the cost of the eligible SI, if desired by CREDA. CREDA reserves right to inspect the material at Godowns / Temporary Stores before dispatch and also at works sites.
- 6) CREDA shall deduct TDS for Income Tax, applicable cess on Civil Work etc. under various acts and deposited with the appropriate authority. Costs and taxes before execution of agreement with CREDA so as to ensure tax deposition as per Government Rules accordingly.

7) ELIGIBLE SYSTEM INTEGRATOR'S DEFAULT LIABILITY -

CREDA may by written notice of default to the eligible SI, terminate the contract in circumstances detailed hereunder -

- (a) If in the opinion of the CREDA, the eligible SI fails to complete the work within the time specified in the Work Order or within the period for which extension has been granted by CREDA to the eligible SI.
- (b) If in the opinion of CREDA, the eligible SI fails to comply with any of the provisions of this contract.
- (c) In the event of CREDA terminating the contract in whole or in part as provided in paragraph (a) above, CREDA reserves the right to engage another eligible SI or agency upon such terms and in such a manner as it may deem appropriate and the eligible SI shall be liable to CREDA for any additional costs or any losses caused to CREDA as may be required for the completion of erection of the SPV SPVPPs and or for penalty as defined under this Bid document until such reasonable time as may be required for the final completion of the work.
- (d) In the event CREDA does not terminate the contract as provided in paragraph (a) the eligible SI shall continue performance of the contract, in which case he shall be liable to CREDA for penalty for delay as set out in this Bid document until the work is completed.

8) FORCE MAJEURE -

The eligible SI shall not be liable for any penalty for delay or for failure to perform the contract for reasons of FORCE MAJEURE such as of God, acts of public, enemy, LWE problems, acts of government, cyclone, fires, floods, epidemics, quarantine restrictions, strikes, freight embargoes provided that if SI shall submit delay notice with appropriate cause of delay to the CREDA in writing within **15 days** of force majeure. CREDA shall verify the facts and may grant such extension as facts justify. Delay in supply of any accessories of Solar system etc. by the related vendors, to whom the Bidder has placed order, shall also not be treated as force majeure.

9) REJECTION OF WORKS -

In the event of any of the material supplied/work done by the eligible SI is found defective in material or workman ship or otherwise not in conformity with the requirements of this contract specifications, CREDA shall either reject the material and/or work and advise the eligible SI to rectify the same. CREDA may impose penalty for such rejection up to the 200% cost of the entire system. Habitual/repeated offenders shall be black listed/debarred to participate in the any Bid/ Activity of CREDA till further orders. The eligible SI on receipt of such notices shall rectify or replace the defective material and rectify the work free of cost. If the eligible SI fails to do so CREDA may -

- a) At its option replace or rectify such defective materials and/or work and recover the extra cost so involved from the eligible SI plus **15%** service charges of the cost of such rectification, from the eligible SI and/ or terminate the contract for balance work/ supplies with enforcement of penalty as stated above.
- b) Defective materials/workmanship will not be accepted under any conditions and

shall be rejected outright without compensation. The eligible SI shall be liable for any loss/damage sustained by CREDA due to defective work **with enforcement of penalty as stated above.**

10) EXTENSION OF THE TIME -

If the completion of installation is delayed due to any reason beyond the control of the eligible SI, the eligible SI shall without delay give notice to the CREDA in writing of his claim for an extension of time. CREDA on receipt of such notice may or may not agree to extend the contract/delivery date of the solar Power Plant System as may be reasonable but without prejudice to other terms and conditions of the contract.

11) PENALTY FOR DELAY IN COMPLETION OF CONTRACT -

If the eligible SI fails to complete the assigned work within the schedule time specified in the Work Order or any extension granted there to, CREDA will recover from the SI as penalty a sum of **One per cent (1%)** of the system price for every delayed system per month. For this purpose, the date of taking over shall be reckoned as the date of completion. The total penalty shall not exceed **5% (Five Per cent)** of the cost.

Review of the progress of installation of SPVPP allocated to SIs shall be done time to time by CREDA and if the progress of installation is found unsatisfactory, the allocation of entire remaining uninstalled SPVPPs or their part of can be re-allocated to other SI as per discretion of CREDA.

12) PENALTY DUE FROM THE ELIGIBLE SI -

All costs of damages and delays for which the eligible SI is liable to the CREDA will be deducted from any money due to the eligible SI including the security deposit of any project under CREDA.

13) ELIGIBLE SI'S RESPONSIBILITY -

Notwithstanding anything mentioned in the specifications of subsequent approval or acceptance of the SPV power plant by CREDA, if any, the ultimate responsibility for satisfactory performance of the entrusted work shall rest with the eligible SI. If in any case the eligible SI does not complete the work as per the Work Orders issued to them then CREDA may take over the task & complete the project at the risk and cost of eligible SI.

14) RESPONSIBILITY TO RECTIFY THE LOSS AND DAMAGE -

If any loss or damage occurs to the work or any part thereof or materials/plant/equipment's for incorporation therein the period for which the eligible SI is responsible for the cause thereof or from any cause whatsoever, the eligible SI shall at his own cost rectify/replace such loss or damage, so that the permanent work confirms in every respect with the provision of the contract to the satisfaction of the Engineer. The eligible SI shall also be liable for any loss or damage to the work/equipment's occasioned by him in course of any operation carried out to him during performing the contract.

15) RESPONSIBILITY TOWARDS THE WORKMAN OR OUTSIDERS -

- The eligible SI shall have to take insurance coverage from any authorized Insurance Company against Workmen compensation due under Workmen Compensation Act and submit copy of the insurance document before issuance of Work Order.
- The eligible SI shall ensure all safety measures during execution and repairs of the work. CREDA, will, in no case be responsible for any accident fatal or non-fatal, caused to any workman or outsider in course of transport or execution or repairs of work.
- All the expenditure including treatment or compensation will be entirely borne by the eligible SIs. The eligible SI shall also be responsible for any claims of the workers

including PF, Gratuity, ESI & other legal obligations.

- SI shall have to submit JCCs within **60 days** after Installation and Commissioning of SPV power plants in District Office of CREDA.

- 16) Contractor shall provide 05 years warranty in installed solar SPVPP from the date of commissioning as per the terms & conditions prescribed in the Bid No.13366/CREDA/HOR/SPVPP/RE-III/2019 dated : 06.11.2019.
- 17) **DECLARATION OF CONFLICT OF INTEREST** - The contractor hereby declares that nobody connected with or in the employment of **CREDA** is not/shall not ever be admitted as partner in the contract.
- 18) (a) The contractor shall arrange insurance coverage for the materials and SPV power plants at his/beneficiary's custody for the work under execution and successful commissioning and subsequent handover to the beneficiary. The contractor shall take up insurance or such other measures for the manpower so as to cover the claim for damage arising under workmen's compensation Act and other applicable State/ Central laws. CREDA shall not bear any responsibility on this account.
 (b) Contractor shall arrange for insurance coverage for SPV power plants and module during COMC period i.e. for 05 years from the date of installation. Insurance should cover for damage and theft. In case of such incidence, SI must replace the lost/damaged part within 7 days.
- 19) The contractor shall abide by the terms and conditions, rules, guidelines, construction practices, safety precautions etc. stipulated in the Bid document including any correspondence between the contractor and the **CREDA** having bearing on execution of work and payments of work to be done under the contract.
- 20) The contractor shall be responsible to follow all the laws including Workmen Compensation Act and all other laws in force & shall be responsible for all the obligations towards labour including EPF, ESI, etc.
- 21) All the taxes deductible at source as per Acts in vogue shall be recovered by **CREDA** and deposited with the appropriate authorities
- 22) Contractor agrees to abide by any decision/instruction passed by the appropriate authority under Anti-profiteering rules notified by the state/central government under GST act.
- 23) Any dispute arising out of the contract shall be subject to the jurisdiction of Hon'ble High Court of Chhattisgarh.

"Herewith everything and anything contained in Bid document no.13366/ CREDA/ HOR/ RE-III/2019 dated : 06.11.2019 is part of this agreement which has been dully signed by both bidder and authorised signatory of CREDA".

In witness whereof the parties present today has hereby entered into agreement.

Signed & sealed on behalf of the above

Named contractor

Name :

Designation :

Signed on behalf of CREDA

Name:

Designation:

Witness:

1. Name:-.....

2.Name:-

.....

Address:-.....

Address:-

.....

SCHEDULE - I

28 PART 'A': GENERAL INFORMATION

(Strike off whichever is not applicable. Separate sheets should be used, wherever necessary)

- | | | | |
|------------|---|---|----------------------|
| 01. | Name & Address of the Bidder | : | |
| 02. | Name & Address of the firm/Company etc. | : | |
| | a) Registered office | : | |
| | b) Factory/works address | : | |
| | c) Fax Nos. | : | |
| | d) Telephone / Mobile Nos. | : | |
| | e) Email id | : | |
| 03. | Confirm whether Bidder is Manufacturer | : | Yes/No |
| 04. | Only manufacturer to give following particulars | | |
| | a) Address of factory | : | |
| | b) Year of starting manufacture | : | |
| | c) Whether same/similar materials
Manufactured earlier
(if yes, give reference) | : | |
| | d) Yearly/monthly production capacity | : | |
| | e) Maximum yearly production
Achieved so far | : | |
| 05. | Whether the firm is SSI Unit of
Chhattisgarh State: | : | Yes/No |
| | a) If yes, write registration No. | : | |
| | b) Whether documentary evidence
Regarding registration enclosed | : | |
| | c) Items for registration | : | |
| | d) Period of registration | : | |
| | d) Whether latest copy Competency/
Certificate furnished | : | Yes/No |
| 06. | Whether the firm is 100% owned by | | |
| | a) State Government | : | Yes/No |
| | b) Central Government | : | Yes/No |
| | If yes, Notification/certificate issued from
The competent authority to this effect is
Enclosed | : | Yes/No |
| 07. | a) Whether the bidder is old participant
with CREDA | : | Yes/No |
| | b) If yes, whether documentary
Evidence is enclosed. | : | Yes/No |
| 08. | Any other information that bidder may like
to give in order to highlight his bid | : | If yes, give details |

PLACE :

SIGNATURE OF BIDDER

NAME IN FULL

DATE :

DESIGNATION/STATUS

FIRM/COMPANY SEAL

29.SCHEDULE - II

PART 'B' : COMMERCIAL INFORMATION

(Strike off, whichever is not applicable. Separate sheets should be used. Wherever necessary)

- 01. i) Earnest Money Details : Bank draft/Bankers cheque payable to "CREDA", Raipur
- ii) Amount of E.M.D. & full details : `
- iii) If exempted, state whether the bidder i / Fully Owned State/Central Govt. Unit : SSI Unit of C.G.
- iv) Reference of documentary evidence regarding exemption enclosed. : Yes/No
- 02. Whether the offer is valid for 6 months from the date of opening of commercial/technical bid. : Yes/No
- 03. Rate of Sales Tax on the date of bid (exclusive in the rate quoted) :
- 04. **DISCOUNT:**
 - a) Whether any rebate/discount is offered. : Yes/No
 - b) If yes, whether the rebate is unconditional/conditional Rate/amount of rebate/discount : Yes/No
 - c) If conditional State condition : Yes/No
- 05. **PAYMENT TERMS:**
Whether CREDA's terms of payment is acceptable to Bidder : Yes/No
- 06. **COMPLETION PERIOD OF WORK:**
Whether Bidder is agreeing for completion period of work as Specified in the Bid : Yes/No
- 07. **PENALTY CLAUSE:**
Whether agreeable to CREDA's Penalty Clause : Yes/No
- 08. Whether agreeable to CREDA's clause of warrantee period : Yes/No
- 09. **SECURITY DEPOSIT:**
Whether Security Deposit clause is understood : Yes/No
- 10. Indicate State, Central Sales Tax Registration NumberState : Yes/No
Central:
(Please Note that in case of non-registration with Commercial Tax, Department Purchase Tax as admissible shall be deducted by the Purchaser from the Bills of the supplier)
- 11. Please mention whether rates offered are applicable for part quantities. : Yes/No

PLACE:

SIGNATURE OF BIDDER

DATE:

NAME IN FULL

DESIGNATION/STATUS

FIRM/COMPANY SEAL

30.SCHEDULE - III

PART 'C' : TECHNICAL INFORMATION

(Strike off whichever is not applicable. Separate sheets should be used. Wherever necessary)

01. Whether material offered is exactly as per technical specification : Yes/No
02. Whether the copies of completion certificate received during last 3 years from other State Nodal Agency or from other Organization for Solar SPVPPing systems (if yes, give details) enclosed. : Yes/No
03. Whether pamphlets/technical details literatures along with drawing etc. furnished with the offer : Yes/No
(if yes, give details)
04. Whether the Bidder agrees to furnish material test certificates in respect of chemical composition and physical properties from Govt./ Govt. approved lab with each batch of supplies. : Yes/No
05. Whether the Bidder has furnished details of manufacturing equipments and short history of plant :
Yes/No (if yes, give details)
06. Whether details of manufacturing process furnished with offer. :
Yes/No (if yes, give details)
07. a) Whether all testing facilities are available. :
Yes/No
If so, give details and in case of non-availability of facilities indicate approved lab available in surrounding areas where tests are proposed to be conducted.

PLACE

SIGNATURE OF BIDDER

DATE

NAME IN FULL

DESIGNATION/STATUS

FIRM/COMPANY

SEAL

31.SCHEDULE - IV
TECHNICAL DEVIATIONS

From,
Bidder Name & Address -

To,
The CE,
CREDA, HO,
Raipur

Sub – Technical Deviations.

Dear Sir,

The technical deviations & variations to the specifications stipulated in the Bid, for the item quoted are as under -

Sl.No.	Condition	Clause No. of Tender Document	Page No. of Tender Document	Statement of deviations and variations
---------------	------------------	--------------------------------------	------------------------------------	---

2. Except aforesaid deviations, the entire order, if placed, on us shall be executed in accordance with your specifications and other conditions. Variation/deviations etc. if found, elsewhere in our offer should not be given any considerations while finalizing the Bid.

PLACE

DATE

SIGNATURE OF BIDDER

NAME IN FULL

DESIGNATION/STATUS

FIRM/COMPANY SEAL

NOTE - Continuation sheet of like size & format may be used as per bidder's requirements and shall be annexed to this schedule.

32.SCHEDULE - V

PAST EXPERIENCE

From :

Bidder's Name & Address -

To,

**The CE,
CREDA, HO,
Raipur**

Sub – Performance/Past Experience.

Dear Sir,

We furnish herewith the record of our performance and experience as follows -

Sl.No.	Purchaser's Name & Address	Order No. Date	Ordered Capacity(KW)	Commissioned Cap (KW)	Value of Order
--------	-------------------------------	-------------------	-------------------------	--------------------------	-------------------

PLACE

SIGNATURE OF BIDDER

DATE

NAME IN FULL

DESIGNATION/STATUS

FIRM/COMPANY SEAL

NOTE - Photocopy of the completion certificate received from other State Agencies/Govt. Undertakings etc. should be enclosed.

33.ANNEXURE – XIII

(EXPERIENCE CERTIFICATE ON THE OFFICIAL LETTER HEAD OF CONCERNED GOVERNMENT DEPARTMENT WITH SEAL AND SIGN BY AUTHORIZED SIGNATORY)

Ref. No.....

Date.....

CERTIFICATE OF COMPLETION - OFF GRID SPV POWER PLANTS

This is to certify that **Name of Bidder, Address of Registered Office** has successfully completed the work of design supply, installation & commissioned ofNos. Off grid SPV power plants(.....Scheme) against various Sanction of Name of Agency at various locations in.....State, as per following details –

S.no	Capacity of solar power plants	Year & Scheme	Total no. system	Remarks
	Total -			

This workmanship and performance of the above installed systems are found satisfactory and are in successful operation.

Seal & Sign
(Authorised Signatory)

34.CONSORTIUM AGREEMENT

This Consortium Agreement executed on this Day of 2019

BETWEEN

M/S, a Company/Proprietorship Firm/Partnership Firm incorporate under the Law of companies Act 1956/2013 and and having its registered/principal office at (GST No.....) through its proprietor S/o (herein after called the “Partner-I”/ “Lead Partner” which expression shall include its successors, executors and permitted assigns)

AND

M/s a Company/Proprietorship Firm/ Partnership Firm under Firm (GST No.) and having its registered/principal office at Through its Partner Mr. S/o (herein after called the “Partner–II”/“Second Partner” which expression shall include its successors, executors and permitted assigns)

For the purposes of submission a pre-qualification bid (hereinafter called “PQ Bid”) and submitting the final bid in case of being pre-qualified in response to Owner’s Pre-qualification document (hereinafter called PQ document) no. **TENDER DOCUMENT NO.....** and entering into a contract in case of award for standardisation of work for Survey, Design, Supply, Installation & Commissioning of Solar Photo Voltaic power plant of various capacities with five years onsite warrantee and insurance anywhere in the state of Chhattisgarh for **ELECTRIFICATION SCHEME of CHHATTISGARH STATE RENEWABLE ENERGY DEVELOPMENT AGENCY (CREDA)**

AND WHEREAS as per PQ document, Consortium bids will also be considered by the Owner provided they meet the specific requirements in that regard.

NOW THIS INDENTURE WITNESSETH AS UNDER -

In consideration of the above premises and agreements all the partners to this Consortium do hereby now agree as follows:

1. We the partners in the Consortium hereby confirm that the name and style of the Consortium shall be “..... /” “Consortium.”
2. **FORMATION AND PRINCIPLE PLACE OF BUSINESS**

FORMATION -

The partner of the consortium do hereby form a Consortium pursuant to the laws of state of Chhattisgarh in order for the consortium to carry on the purposes for which provision is made herein

PRINCIPAL PLACE OF BUSINESS -

The Consortium Partner shall maintain principal place of business at The partners of the consortium may re-locate its office from time to time or have additional offices as the partners may determine

3. PURPOSE OF THE CONSORTIUM -

The object of the consortium to bid and perform Tender Nofrom CHHATTISGARH STATE RENEWABLE ENERGY DEVELOPMENT AGENCY (CREDA) For Survey, Design, Supply, Installation & Commissioning of Solar Photo Voltaic power plants of Various Capacities with Five Years on Site warrantee & Insurance anywhere in the state of Chhattisgarh for electrification Scheme and to deal with the same in any manner what so ever.

4. TERM -

The term of the consortium shall commence as of the date hereof and shall be terminated and dissolved upon the earliest to occur of (i) on mutual understanding of partners by executing separate agreement regarding dissolution of consortium (ii) the unanimous agreement of the partners (iii) the order of a court of competent jurisdiction (iv) Competition of the above mention tender

5. PERCENTAGE OF PARTICIPATION -

CONSORTIUM PARTNER	PARTNER	PERCENTAGE
1) M/S	Lead Partner (Partner 1)
2) M/s	Other Partner (Partner 2)
TOTAL -		

6. PARTICIPATION -

Both the partners have decided to perform the above mention work of CREDA in their above proportionate work.

7. The Lead Member is hereby authorized by the all Member of the Consortium to bind the Consortium and receive instructions for and on their behalf.
8. The Lead Member shall be liable and responsible for ensuring the individual and collective commitment of each of the Members of the Consortium in discharging all of their respective obligations. Each Member further undertakes to be individually liable for the performance of its part of the obligations without in any way limiting the scope of collective liability envisaged in this Agreement.
9. Subject to the terms of this Agreement, the all member shall be responsible for providing technical and financial support and responsible equally for execution of project as per agreement to be signed.
10. Both the Partners shall be jointly responsible for Project Management of works.
11. In case of any breach of the said Contract by any of the partners of the CONSORTIUM, we hereby agree to be fully responsible for the successful execution/performance of the Contract in accordance with the terms of the Contract.
12. Further, if the Owner suffered any loss or damage on account of any breach of the Contract or any shortfall in the completed equipment/ plant, meeting the

guaranteed performance parameters as per the technical specifications/ contract documents, the Lead Partner and Second Partner of these presents undertake to promptly make good such loss or damage caused to the Owner, on the Owner's demand without any demure.

- 13. The financial liability of the partners to this Consortium Agreement, to the Owner with respect to the any or all claims arising out of the performance or non-performance of the Contract shall, however be not limited in any way so as to restrict or limit the liabilities of either of the partner.
- 14. This Consortium Agreement shall be governed, construed and interpreted in accordance with Laws of India. Courts of Raipur (C.G.) shall have exclusive jurisdiction in all matters arising there under.
- 15. It is further agreed that this CONSORTIUM Agreement shall be irrevocable and shall form an integral part of the Contract and shall continue to be enforceable till the Owner discharges the same. It shall be effective on the date first above mentioned for all purposes and intents.

IN WITNESS WHEREOF, the partners to this Consortium agreement have, through their respective authorized representatives, have executed these presents and affixed their hands and common seal of their respective companies on the day, month and year first above mentioned.

FOR, M/s

FOR,M/s

(MR.)
.....)

(MR.

Lead Partner/Partner-1

Other Partner/Partner-2

WITNESS -

WITNESS -

1.....

1.....

2.....

2.....

35. Benchmark cost of solar Power Plant

S no	Category	Details of solar power plant	Bench mark price for supply of material for solar power plant including Module,battery, Hybrid Inverter ,Structure,PCU,Structure Earthing,LA and other complete BOS material Exe. GST(In.Rs)	Bench mark price for complete installation and commissioning of solar power plant Ex.GST(In Rs.)	Bench mark Total Price (In Rs.)Ex GST
		Module cap./Battery Bank Cap./Battery Bank Voltage	A	B	C=A+B
1	A	600W/120AH/24V	37600	14339	51939
2		1200W/120AH/48V	75200	28678	103878
3		2400W/240AH/48V	150400	57356	207756
4		3000W/400AH/48V	188000	71695	259695
5	B	3600W/360AH/48V	225600	86034	311634
6		4800W/240AH/48V	300800	114712	415512
7		6000W/300AH/96V	376000	143390	519390
8		7200W/360AH/96V	451200	172068	623268
9		9000W/ 600AH/ 120V	564000	215085	779085
10	C	10500W/ 600AH/ 120V	588000	224237	812237
11		12000W/480AH/120V	672000	256271	928271
12		15000W/400AH/240V	840000	320339	1160339
13		18000W/360AH/240V	1008000	384407	1392407
14		21000W/400AH/240V	1176000	448475	1624475
15		24000W/480AH/240V	1344000	512542	1856542
16		30000W/600AH/240V	1680000	640678	2320678
17		36000W/720AH/240V	2016000	768814	2784814
18		48000W/960AH/240V	2688000	1025085	3713085
19		51000W/800AH/240V	2856000	1089153	3945153
20		60000W/1200AH/240V	3360000	1281356	4641356
21		80000W/1200AH/240V	4331933	1856543	6188475
22		102000W/1000AH/240V	5712000	2178305	7890305
23		120000W/1200AH/240V	5920000	2257627	8177627
24	120000W/2400AH/240V	6720000	2562712	9282712	

Drawing Section

Complete Drawing of Elevated Module Mounting Structure & Civil Works

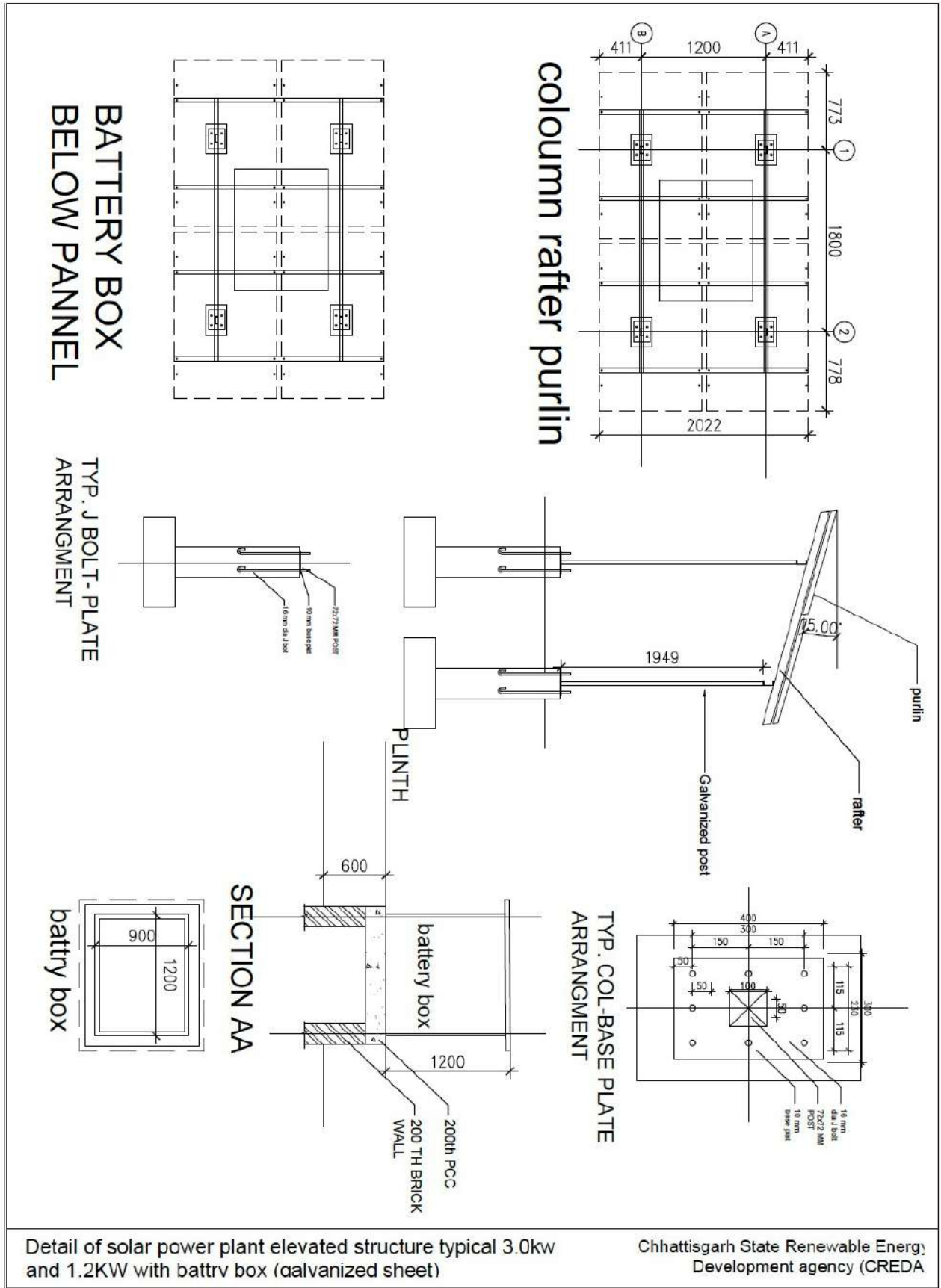

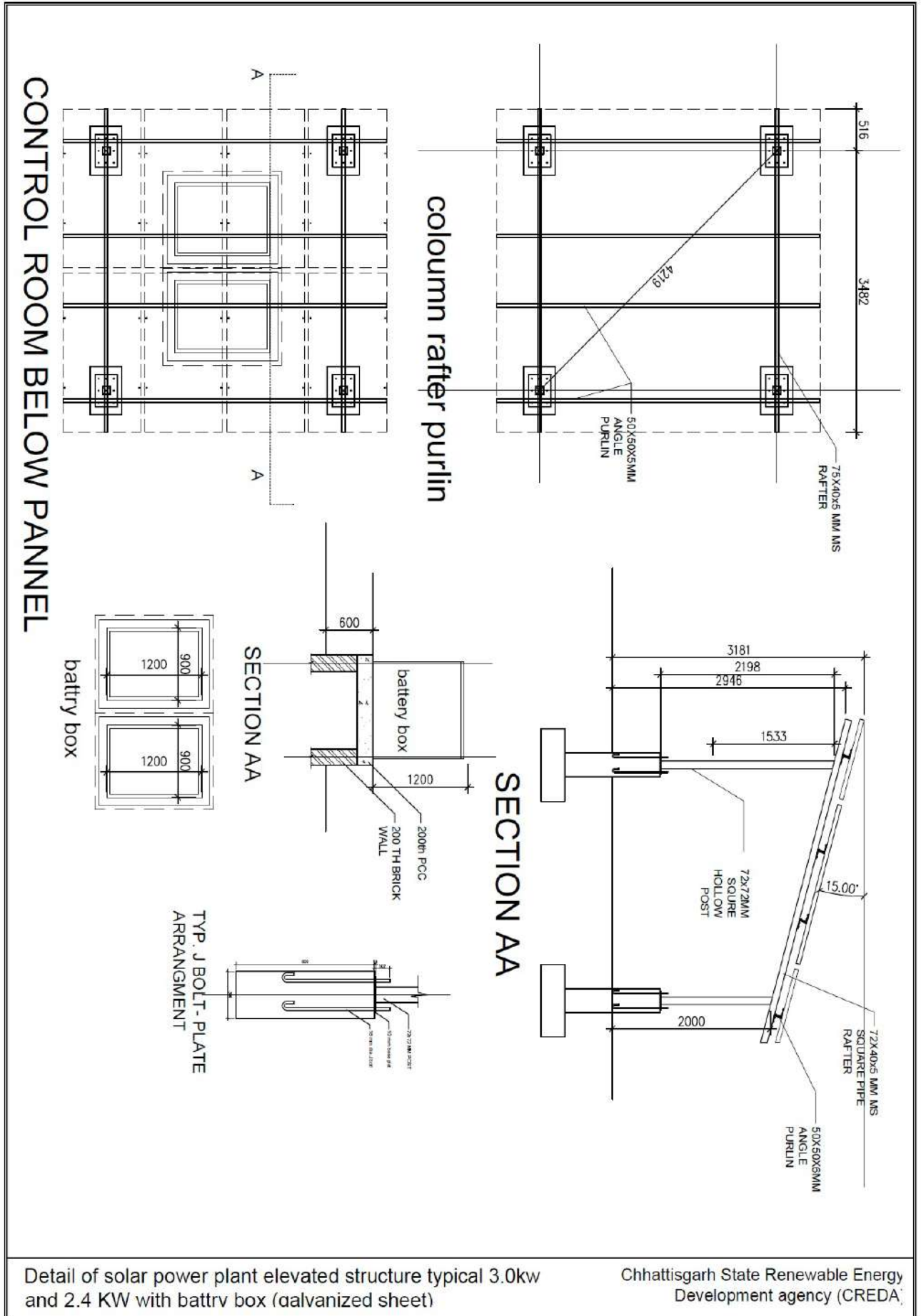

Detail of solar power plant elevated structure typical 3.0kw and 2.4 KW with battry box (galvanized sheet)

Chhattisgarh State Renewable Energy Development agency (CREDA)

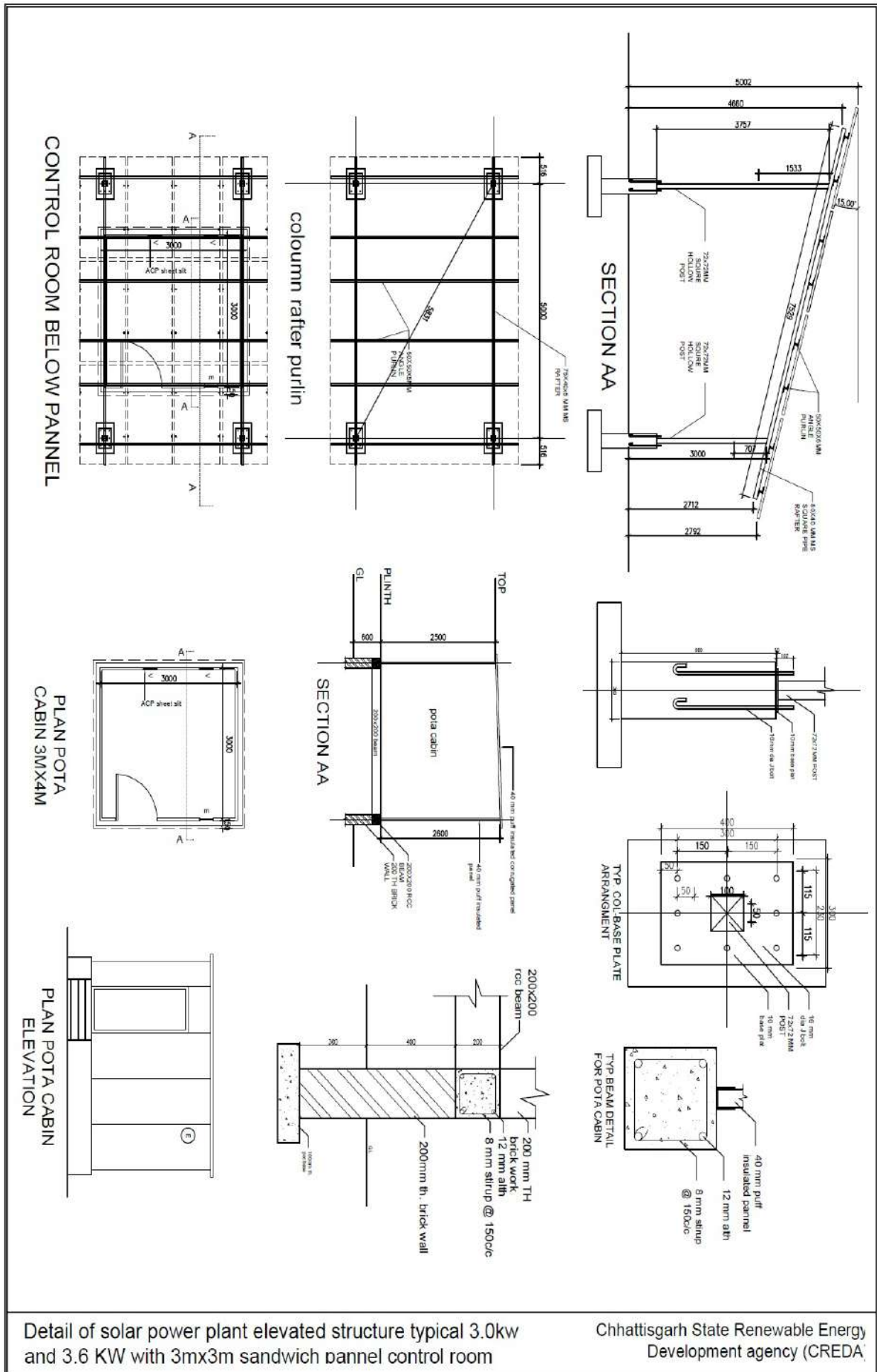

Detail of solar power plant elevated structure typical 3.0kw and 3.6 KW with 3mx3m sandwich pannel control room

Chhattisgarh State Renewable Energy Development agency (CREDA)

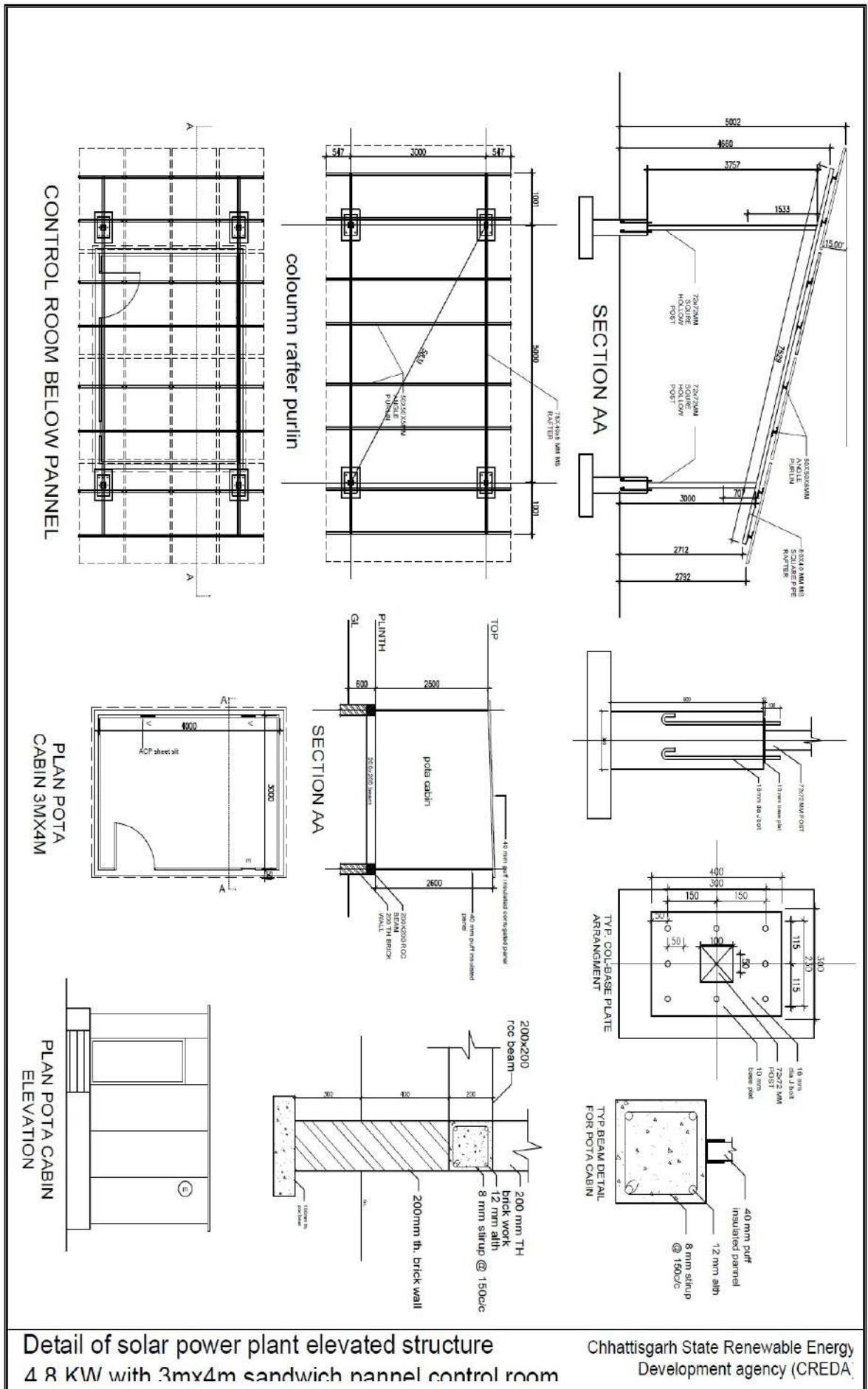

Detail of solar power plant elevated structure
4 R KW with 3mx4m sandwich pannel control room

Chhattisgarh State Renewable Energy
Development agency (CREDA)

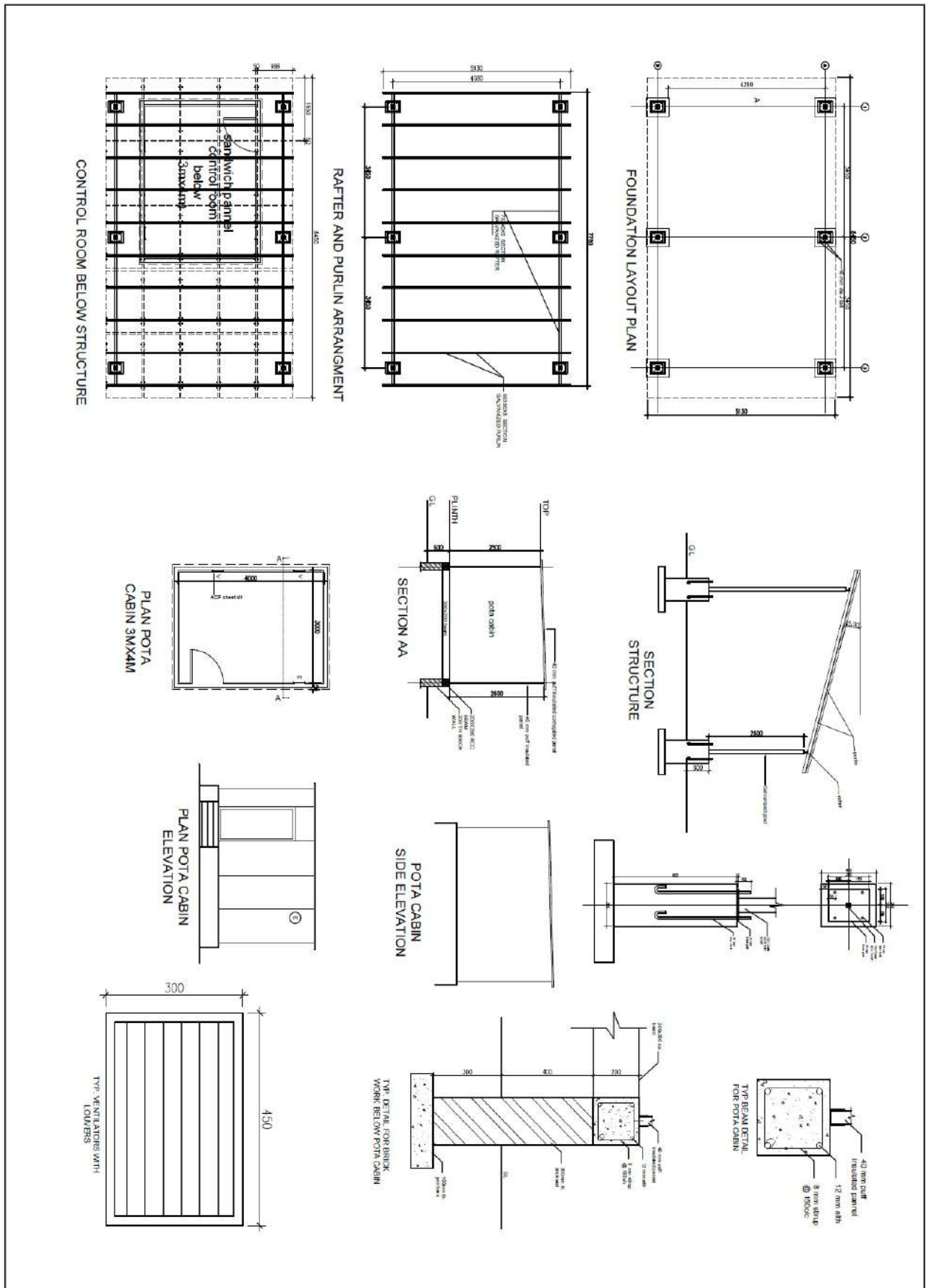

Detail of solar power plant elevated structure typical for 6.0kw with 3mx4m sandwich pannel control room

Chhattisgarh State Renewable Energy Development agency (CREDA)

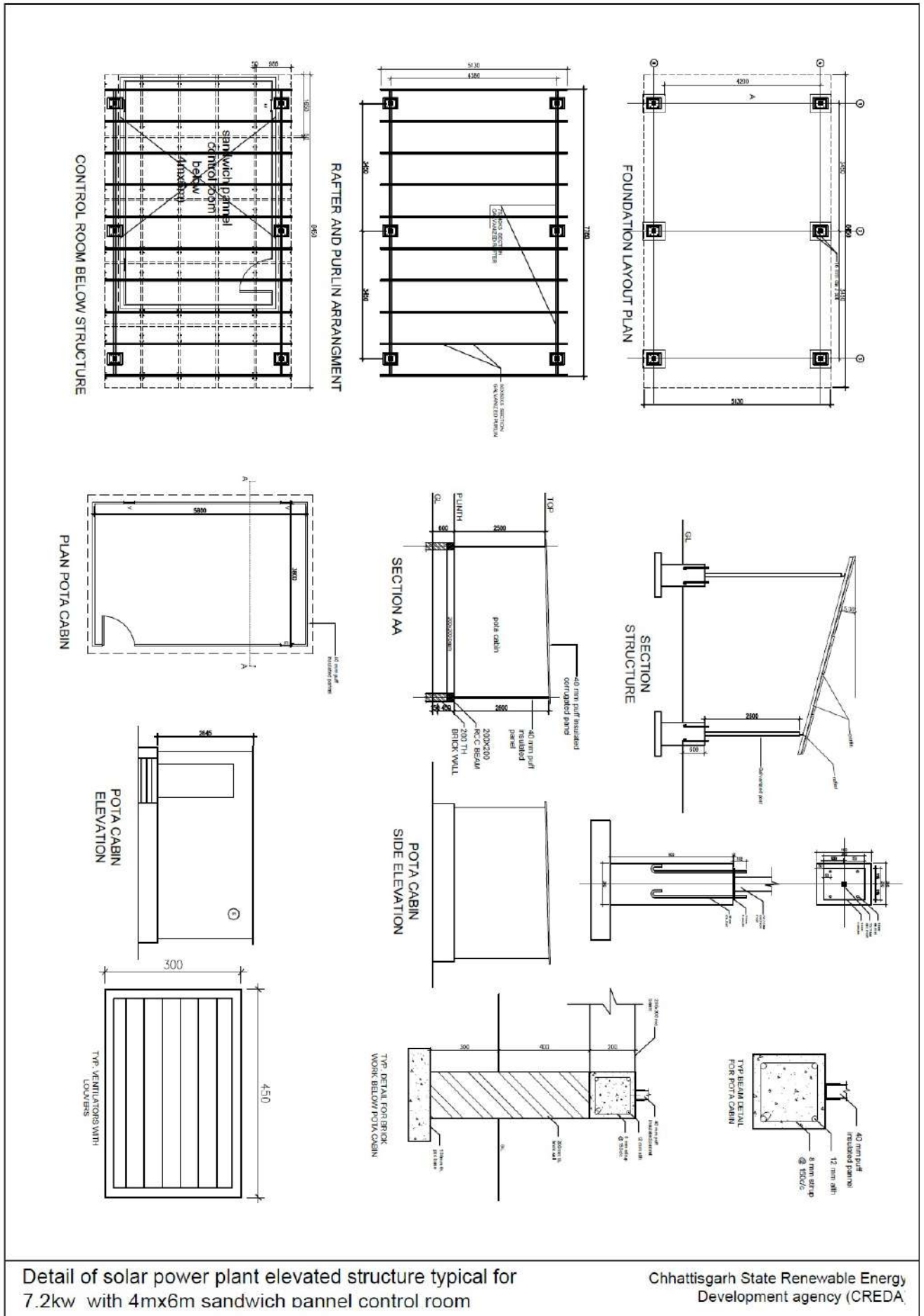

Detail of solar power plant elevated structure typical for 7.2kw with 4mx6m sandwich pannel control room

Chhattisgarh State Renewable Energy Development agency (CREDA)

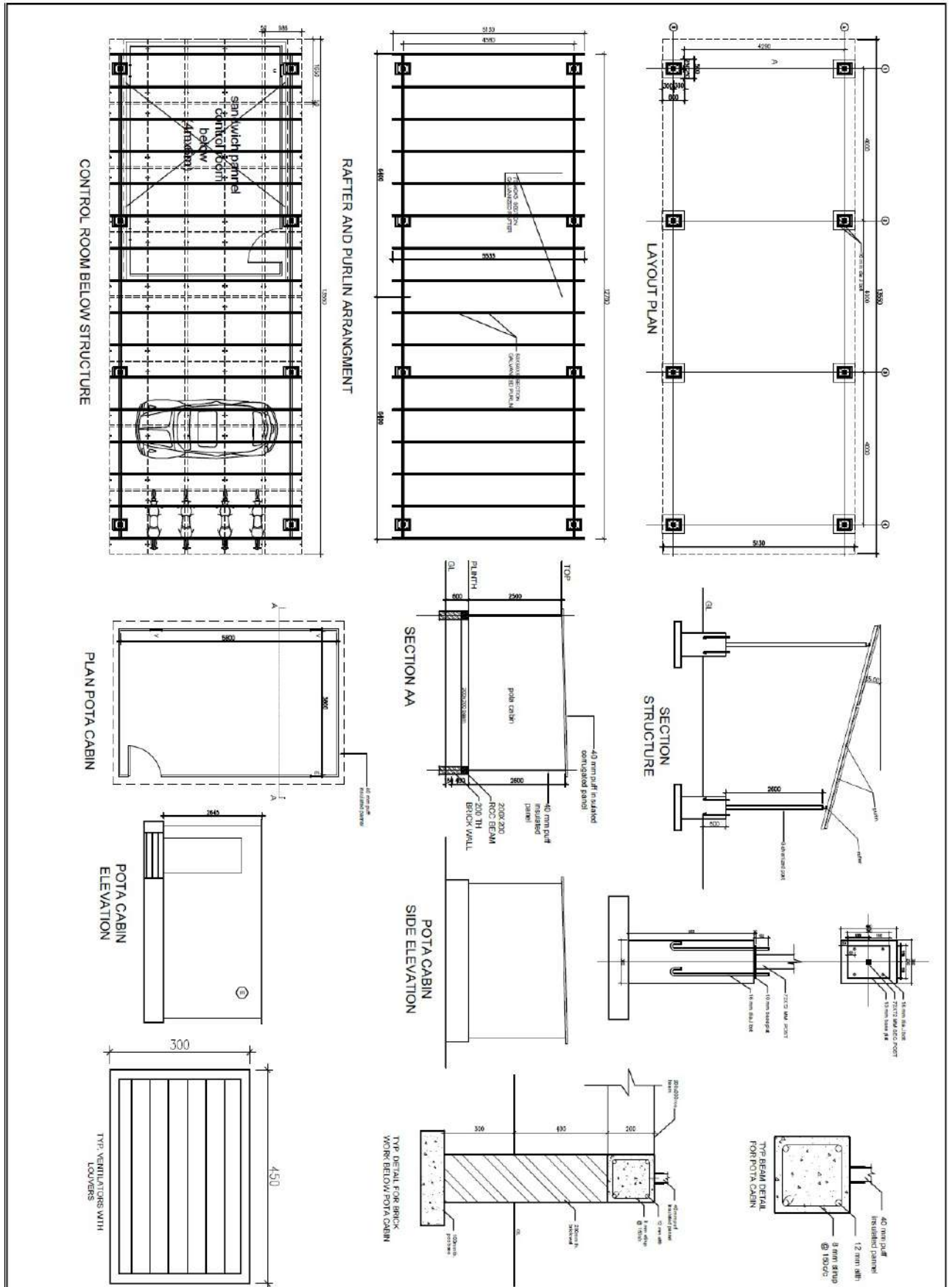

Detail of solar power plant elevated structure typical for 9kv and 10 KW with 4mx6m sandwich pannel control room

Chhattisgarh State Renewable Energy Development agency (CREDA)

AJB 4 INPUT 1 OUTPUT

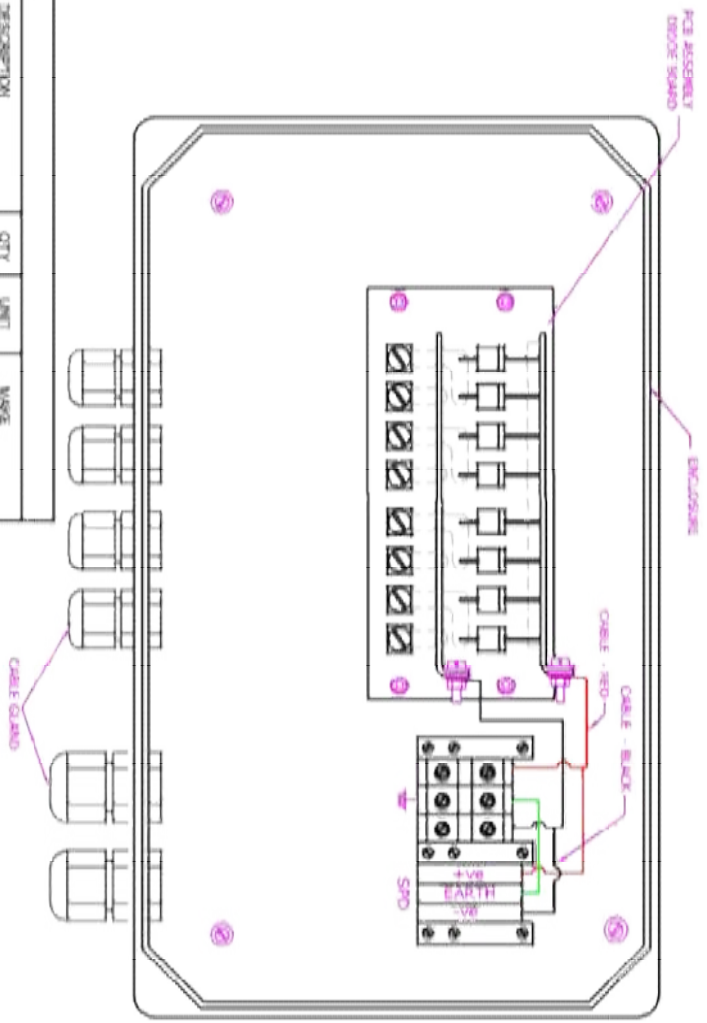

BILL OF MATERIALS				
SLNO	ITEM DESCRIPTION	QTY	UNIT	MARK
1	DIODE PCB BOARD 180V/DC, 20 AMPERE BLOCKING DIODE WITH NECESSARY BUSBAR ARRANGEMENT	01	Nb	REPUTED
2	SMD 180V/DC TYPE 2, ARRESTING CAPACITY TO 40KA	01	Nbs	GEOPROPER/SONNER/REPUTED
3	MSD PPS ENCL. OSURE (180V, 180V/200V/400V) ELECTRICAL DIMENSIONS	01	Nb	KEENSEL/REPUTED
4	PRE-CABLE GLANDS	01	LOT	JACOBERBOX
5	COPPER TERMINAL BLOCKS FOR INPUT AND OUTPUT TERMINATIONS	01	LOT	PHOENIX/REPUTED

MOUNTING ACCESSORIES				
SLNO	DESCRIPTION	QTY	UNIT	MARK
1	O-RING HEAD INSULATION WITH PLAIN WASHER AND NUT SS304	04	Nbs	REPUTED



Chhattisgarh State Renewable Energy Development Agency
(Department of Energy, Govt. of Chhattisgarh)



AJB 4 INPUT 1 OUTPUT

AJB 6 INPUT 1 OUTPUT

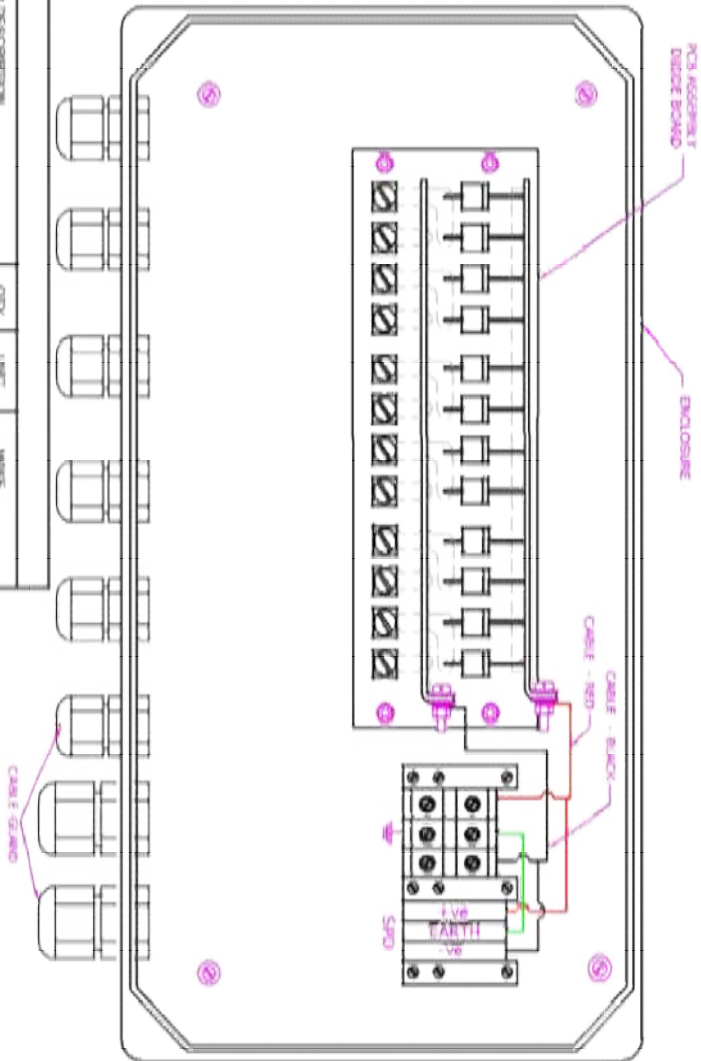

BILL OF MATERIALS

S/NO	ITEM DESCRIPTION	QTY	UNIT	MARK
1	DICE PCB SOLDER 900V DC 20 AMPERE BLOCKING DIODE WITH NECESSARY RESISTOR ARRANGEMENT	01	No	REPORTED
2	SPD 180V/DC TYPE 2, ARRESTING CAPACITY 70 kVA	01	No	ORCHENBAU SCHNIDER/REPORTED
3	ABS PANEL ENCLOSURE (280x145x70x) 134-1mm (TYP J)	01	No	WENZEL/REPORTED
4	PGS CABLE GLANDS	01	LOT	JACOBI/TERRIX REPORTED
5	CONVERT TERMINAL BLOCKS FOR INPUT AND OUTPUT TERMINATIONS	01	LOT	PHOENIX/REPORTED

INSTALLING ACCESSORIES

S/NO	DESCRIPTION	QTY	UNIT	MARK
1	CHEESE HEAD WASHERS WITH PLAIN WASHER AND NUT SETS	14	No.	REPORTED



Chhattisgarh State Renewable Energy Development Agency
(Department of Energy, Govt. of Chhattisgarh)



AJB 6 INPUT 1 OUTPUT

MJB 2 INPUT 1 OUTPUT

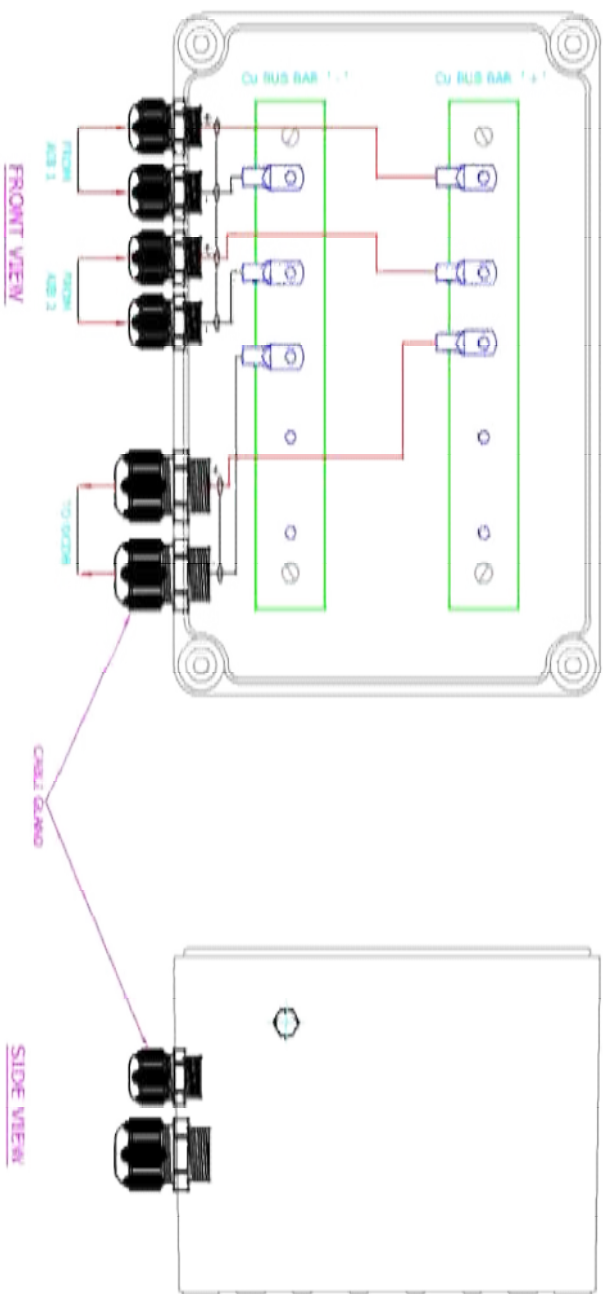

BILL OF MATERIALS

S/LNO	ITEM DESCRIPTION	QTY	UNIT	MARK
1	INDUSTRIAL GRADE Tinned-Copper BUSBAR	02	M	REPUTED
2	ABS PROT ENCL(COLOUR GRAY) 180MM*130*90mm	01	NO	HENSEL/RECHAUFFOUR REPUTED
3	PEB-CABLE GLANDS	04	LOT	REPUTED

MOUNTING ACCESSORIES

S/LNO	DESCRIPTION	QTY	UNIT	MARK
1	DRIBBE HEAD BRACKETS WITH PLAIN WASHER AND NUT SS304	04	NIL	REPUTED



Chhattisgarh State Renewable Energy Development Agency
(Department of Energy, Govt. of Chhattisgarh)



MJB 2 INPUT 1 OUTPUT

EARTHIG KIT

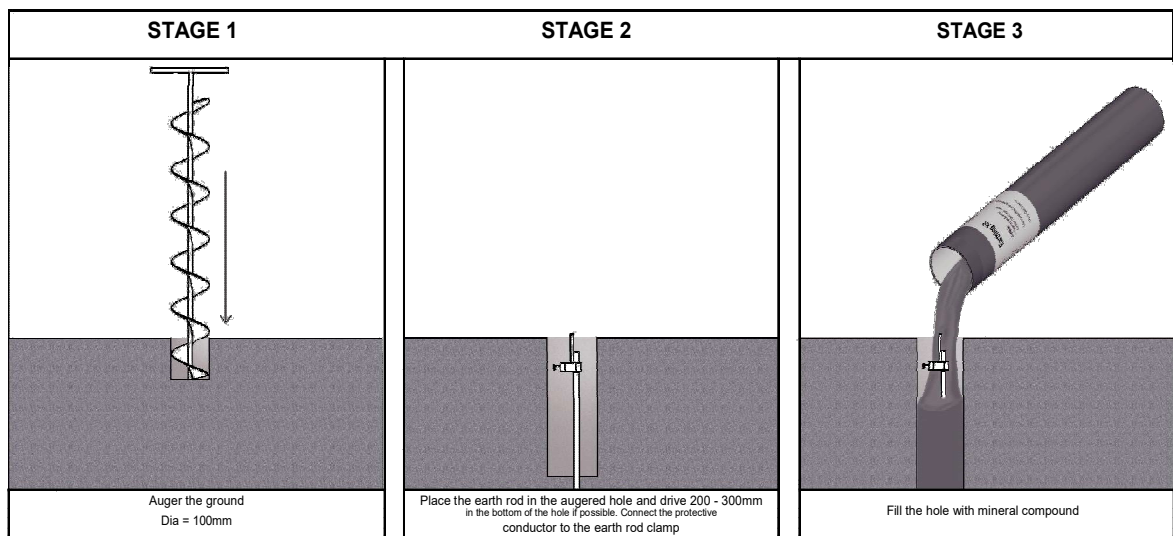
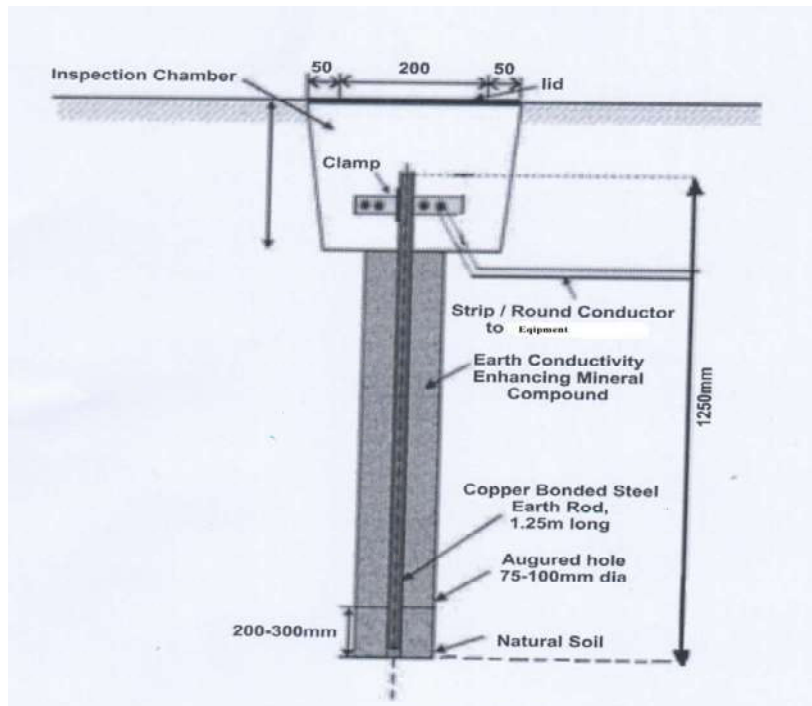

EARTHING KIT & INSTALLATION DETAILS