



**Chhattisgarh State Renewable Energy
Development Agency (CREDA)**
(Dept. of Energy, Govt. of Chhattisgarh)

Near Energy Education Park, Village Fundhar
VIP (Air Port Road) Raipur 492015 (C.G.) Ph.: +91-8370009925, 7717112459
E-mail: sdp.credaho@gmail.com, Website: creda.co.in

Tender Document

TENDER No. 15537/CREDA/HOR/See-Saw Pump/2020-21

DT. 05.02.2021

TENDER FOR STANDARDISATION OF RATES FOR SUPPLY, DESIGN, INSTALLATION, COMMISSIONING OF SEE SAW WATER PUMPING SYSTEMS, WITH 2KL TANK, WITH FIVE YEARS COMC & ON SITE AND UNCONDITIONAL WARRANTEE ANYWHERE IN STATE OF CHHATTISGARH.

Particulars	From Date & Time	To Date & Time	Place
Date of issue of notice inviting bid	05.02.2021 05:00 pm	----	----
Submission of Pre Bid queries in writing	16.02.2021 11:00 am	16.02.2021 05:00 pm	At H.O. CREDA, RE-V, Section
Submission samples & Inspection of sample Materials by Bid Committee as per Valid Test Report and Submission of Summary of Test Report and M.A.F.	26.02.2021 11:00 am	26.02.2021 03:00 pm	At H.O. CREDA, VIP Road, Raipur
Submission of sealed tender	05.03.2021 11:00 am	05.03.2021 01:00 pm	At H.O. CREDA, RE-V, Section.
Opening of Tender & financial Bid	06.03.2021 From 02:00 pm	----	At H.O. CREDA, RE-V, Section

***Bid Document Cost– Rs.5,000.00 + 18% GST = Rs.5,900.00
(in words-Rupees Five Thousand Nine Hundred Only)***

Document can also be downloaded from our website www.creda.co.in with the cost of Bid as mentioned in NIT, which shall have to be deposited along with the Bid document.

CHATTISGARH STATE RENEWABLE ENERGY DEVELOPMENT AGENCY
CONTENTS

See-Saw Water Pumping system

SN	Section	Description	Page no.
1		Cover Page, Contents etc.	1-2
2		Notice Inviting BID	3
3		Check List	4
4		Details of EMD and Bid Fee	4
5		Undertaking of the Bidder	5
6	SECTION - 1	Instruction For Bidder, Eligibility Criteria, Consortium/Start-Up/New Entrepreneur/Bidding Process, EMD/Submission of Documents/Specific Amendments/GST&TIN, /Bid/Analysis of Rate/Registration of Bidder etc.	6-9
7	SECTION - 2	General Condition of Contract	10-15
8		Definitions/Proof of Manufacturer/Contract Document/Manner	10
9		Variations, Additions & Omissions/Inspection/Completion	11-12
10		Eligible SI Default Liability/Force Majeure/Rejection of works, terms of payment, penalty, allocation of work etc.	13-15
11	SECTION - 3	Scope of Work	16-17
12	SECTION - 4	Specifications for See-Saw Water Pumping Systems	18-25
13	SECTION - 5	Drawings	26-33
14	SECTION - 6	Installation & Commissioning of system	34
15	SECTION - 7	Price Bid & Agreement	35-39
16	SECTION - 8	Benchmark Cost	40
17	SCHEDULE-I	General Information	41
18	SCHEDULE-II	Commercial Information	42
19	SCHEDULE-III	Technical Information	43
20	SCHEDULE-IV	Technical Deviation	44
21	SCHEDULE-V	Past Experience	45
22	SCHEDULE-VI	Certificate of Completion	46
23	FORM "A"	Site Selection form	47
24	FORM "B"	Site Selection criteria	48
25	FORM "C"	Plan of site	49
End of the Document			50

TENDER No. 15537/CREDA/HOR/See-Saw Pump/2020-21

DT. 05.02.2021

NOTICE INVITING BID

CREDA invites sealed Bids for Standardisation of Rates for Supply, Design, Installation, Commissioning of See Saw Water Pumping Systems, with 2KL water Tank, with on Site and unconditional warrantee anywhere in the state of Chhattisgarh from registered System Integrators of CREDA for See-Saw Water pumping system, as per following details –

SN	Item Description	Approximate Quantity	Cost of Bid Document	EMD
I.	06 seater See-Saw water pumping system with 3 meters staging Structure and 2000 Litres water storage tank, 05 year COM, stand post, Soakage pit, onsite warrantee, Insurance etc. for anywhere in the State of Chhattisgarh	500 Nos.	Rs 5,000.00 + 18% GST = Rs.5,900.00	Rs.5,00,000.00
TOTAL		500 Nos.	5,900.00	Rs. 5,00,000.00

The quantity of pumps mentioned in above table may vary as per actual site conditions and demand.

Important Events and time schedule for this Bid are as follows –

Particulars	From Date & Time	To Date & Time	Place
Date of issue of notice inviting bid	05.02.2021 05:00 pm	----	----
Submission of Pre Bid queries in writing	16.02.2021 11:00 am	16.02.2021 05:00 pm	At H.O. CREDA, RE-V, Section
Submission samples & Inspection of sample Materials by Bid Committee as per Valid Test Report and Submission of Summary of Test Report and M.A.F.	26.02.2021 11:00 am	26.02.2021 03:00 pm	At H.O. CREDA, VIP Road, Raipur
Submission of sealed tender	05.03.2021 11:00 am	05.03.2021 01:00 pm	At H.O. CREDA, RE-V, Section.
Opening of Tender & financial Bid	06.03.2021 From 02:00 pm	----	At H.O. CREDA, RE-V, Section

Estimated Value of tender:-Rs.18.00 Crore (may be changed as per Budget availability)

The sealed tender forms shall only be submitted on the last date **05.03.2021 up to 01:00 PM** at the Tender Submission Box Kept at CREDA Head Office, Tender Cell (RE-V), VIP Road, Near Energy Park, Raipur (C.G.), Any Tender Document received through any other means shall not be accepted.

Financial bid may be opened only after scrutiny of technical bid on the same day or may be on other day, as per the decision of Tender Committee. Interested parties can participate in the tender as per the above description according to the eligibility criteria.

Details of this tender are mentioned at Tender Documents, which can be downloaded from our website www.creda.co.in. The tenderer should have to deposit tender document cost, along with EMD as mentioned above through demand draft payable to “**CREDA Raipur**” while submitting tender.

Tenderers are requested to submit Pre-Bid queries/suggestions/objections/reservations if any with details so as to avoid any confusion and to ensure clarity and transparency regarding the tender.

CREDA reserves all rights to accept/reject any or all tenders in full/part without assigning any reasons. **Any Amendments in the tender shall only be notified through only the website of CREDA i.e. www.creda.co.in**

**Chief Engineer
RE-V, H.O. CREDA
Raipur (CG)**

CHECK LIST

To ensure that your Bid submitted to CREDA is complete in all respects, please go through the following checklist & tick mark for the enclosures attached with your Bid –

Sl. No.	Description	Complied	Page No. / Flag
1.	Earnest Money Deposit		
2.	Bid Document Fee (proof of submission)		
3.	The original document duly signed & with stamp on each page, as a confirmation of acceptance of Terms & Conditions (T&C).		
4.	Copy of Registration Certificate as System Integrator of CREDA in SPV Programme valid for FY 2020-21.		
5.	Net Worth Certificate and Turnover Certificate duly signed by Chartered Accountant		
6.	Copy of certificate for last three years turnover of works done		
7	Completion and Performance Certificates of See-Saw Pumping system installed by the Bidder in Govt Scheme of any state or Market Mode Scheme of CREDA.		
8	Declaration of conflict of interest - by bidder about any relatives working with CREDA.		
9	Manufacture Authorization certificates of major components of See-saw pumping system.		
10.	Forwarding Letter & Undertaking by the Bidder		
11.	PAN, GSTIN, Copy of ITRs for last three FY of the Bidder		
12.	Undertaking on indigenouness of components		
13.	Self-certificate from Bidder on not being a debarred from Government contract or a blacklisted company.		
14.	Undertaking for the remaining test reports (for which acknowledgements have been submitted) submission within 90 days from the date of agreement.		

Details of EMD and Bid Fee

SN	Description
1.	<p>Earnest Money Deposit - Earnest Money Deposit of Rs., submitted in the form of Demand Draft / Banker's Cheque/RTGS/NEFT from any scheduled bank drawn on _____ Bank _____ Branch, bearing DD/BC No. _____ dated _____ is attached herewith.</p>
2.	<p>Bid Document Fee - Bid Document Fee of Rs., submitted in the form of Demand Draft / Banker's Cheque/RTGS/NEFT from any scheduled bank drawn on _____ Bank _____ Branch, bearing DD/BC No. _____ dated _____ is attached herewith.</p>

(Sign & Seal of the Manufacturer)

UNDERTAKING OF THE BIDDER

I/We have read carefully and examined the notice inviting Bid, schedule, General Rules and terms and conditions of the contract, special conditions, Schedule of Rates and other documents and Rules referred to in the Bid document for the supply.

I/We hereby Bid my rates for the execution of the work for CREDA as specified within the time stipulated in the schedule in accordance with all aspects with the specifications, designs, drawings and instructions with such conditions so far as applicable.

I/We agree to keep the Bid valid for **One Hundred Eighty (180) days** from the due date of submission thereof and not to make any modifications in its terms and conditions.

A sum of **Rs.....** is hereby forwarded as **Earnest Money** in the form of crossed demand draft / RTGS / NEFT payable to CREDA at Raipur (C.G.). If I/We, fail to commence or complete the Work Ordered in specified time or fail to fulfil the any condition of Bid document, I/We agree that the CREDA shall, without prejudice to any other right or remedy, be at liberty to forfeit the said Earnest Money absolutely. The said Earnest Money shall be retained by CREDA towards security deposit to execute all the works referred to in the Bid documents upon the terms and conditions contained or referred to therein and to carry out such deviations as may be required by CREDA.

I/We hereby declare that I/We shall treat the Bid documents, specifications and other records connected with the work as secret/confidential and shall not communicate information derived there from to any person other than a person to whom I/We have authorized to communicate the same or use the information in any manner prejudicial to the safety of CREDA/Government.

I/We shall abide to all the laws and shall be responsible for making payments of all the taxes, duties, levies and other Govt. dues etc. to the appropriate Govt. departments.

Our GST Registration No. The PAN No. under the Income Tax Act is

I/We shall be responsible for the payment of the respective taxes to the appropriate authorities and should I/we fail to do so, I/we hereby authorize CREDA to recover the taxes due from us and deposit the same with the appropriate authorities on their demand.

Dated:

Signature

Place:

Name of Bidder with seal

Witness:

Signature:

Name:

Postal Address:

.....

SECTION - 1

INSTRUCTIONS FOR BIDDERS

1. ELIGIBILITY CRITERIA:

A. TEST REPORTS OF SEE-SAW SYSTEM

Bidder must have valid test report or certification of seesaw Pumping system or major items used in system like- Cylinder, Water tank, tank Structure etc. They will have to provide copy of such test report or certification of their equipment.

Bidder should have test certificate for the offered equipment valid at the time of opening of the bid as per specifications mentioned in this Bid document and guidelines.

B. MINIMUM EXPERIENCE

Bidders must have minimum experience of supply, installation & commissioning of 01 nos. of see-saw pumping system as per the specifications till the time of tender submission date.

Bidders will have to submit satisfactory commissioning/functioning report containing complete system details from the concerned state/central agencies /department along with bid document. (Experience in terms of works done for other private / non Govt. companies/ firms etc. shall not be considered). **Bidder registered as a Pvt. Ltd. / Ltd. / Partnership / Proprietorship firm incorporated/registered in the State of Chhattisgarh shall be treated as Bidder of Chhattisgarh.**

C. Bidders should be SSI units having facilities of fabrication and manufacturing of the allied works.

D. Experience Certificate submitted should be in attached format (as per Schedule-V & VI) **shall be considered only in-case of submitted in Hindi / English Language only.** Work order, L.O.I. / L.O.A etc., will not be acceptable.

E. Bidders must have a Positive Net worth of **Rs.25 Lacs as on 31st March 2020 (which is defined as “Net value of the Assets minus (-) Net value of liabilities”)**. They shall have to submit a **Certificate** duly signed by a qualified and registered Chartered Accountant having UDI number as a proof. Produced certificate must tally with the audited balance sheet.

F. Bidders should have an aggregate turnover of minimum **03 Crores** in last three years i.e. 2017-18, 2018-19 & 2019-20 in SPV Projects or allied works. Certified copies of the annual returns and audited balance sheet submitted to the Registrar of Companies/ Income Tax Authorities should be enclosed. For the preceding years **Summarised Sheet** of turnover certified by registered CA must be enclosed.

G. Bidder who is debarred from business by Govt. /Govt. Agency in any state would not be eligible to participate in this bid. A self-declaration should be submitted by the bidder to this effect, failing which bid shall be rejected.

2. CONSORTIUM/JOINT VENTURE & START-UP & ENTERPRENEUR - Consortium or Joint Venture & Start-up, new Entrepreneur are not allowed in this Tender.

3. SAMPLES -

Samples of complete see-saw pumping systems including - cylinder, water tank & stand post, taps should be displayed for examination before **03:00 PM dated 26.02.2021** at CREDA Head office Raipur. These will be examined by Technical Committee of CREDA on **26.02.2021** and Bidders will be shortlisted on the basis of approval of the Technical bids and samples along with Test Report for opening of price bids.

4. SUBMISSION OF DOCUMENTS -

Documents should be submitted in prescribed manner in separate envelopes as follows-

A. Main Envelope: Main Envelope must enclose all A, B, C, D & E envelopes. Bidder Name, Address and status of firms should be clearly written on main envelope.

B. Envelope-(A): Bid Fees and EMD.

C. Envelope-(B): Financial Eligibility Documents: Net worth & Turnover certificate.

D. Envelope-(C): Technical Eligibility Documents: Experience certificates, Test Reports & Summary of Test Reports and Manufacturer Authorization Form.

E. Envelope-(D): Complete Bid document in original duly seal & signed by authorized signatory on each & every page of the Bid document.

F. Envelope-(E): Price Bid.

Bid Document which doesn't follow the above format shall be disqualified.

7. SPECIFICATION AMENDMENTS -

The Specifications of cylinder, Tank, Structure, Stand Posts, Taps etc. should be as per as specified in the Bid. If any amendments are issued by CREDA in due course of time, in this context, then those shall be applicable under this Bid.

8. GST & PAN -

Bidder shall have to submit copies of GST registration number and PAN numbers issued by the appropriate authority.

9. THE BID -

Technical Bid must be deposited in the Bid box only kept in the Chief Engineer RE-V Section, CREDA, H.O., Raipur till **01:00 PM on date 05.03.2021**. Nobody is authorized to receive or grant receipt for Bid delivered on behalf of CREDA. Bid received through any other means shall not be considered.

10. ANALYSIS OF RATE-

- A. Bidder should quote their rates considering variation of site conditions and all other factors in price of different components and keeping the quantum and quality of work in mind. Every care has been taken in preparing the cost estimation i.e. Benchmark Cost (Section-8) however, these are for guidance purpose only.
- B. The benchmark cost of CREDA is Exclusive of GST and the bidder has to quote the price without GST. The rates will be compared without GST.
- C. If the successful bid is unbalanced in relation to the benchmark cost of CREDA as stated in Section-8 by less than 10%, the successful bidder shall have to provide Additional Performance Security (APS) to the extent of difference of 90% of benchmark cost and rates quoted by the successful bidder for total allocable quantity in such categories in which he has submitted unbalanced bid, in the form of Demand Draft/RTGS issued by approved scheduled bank in favour of CREDA, before signing the agreement. The same shall be released along with the normal SD after 05 years of agreement.
- D. In case the bidder refuse to deposit Additional Performance Security (APS) then his bid will be rejected by the sanctioning authority and earnest money shall be forfeited and shall be blacklisted /debarred to participate in any tender/ activity of CREDA until further orders. In such case CREDA shall have discretionary rights to decide reasonable rates in comparison to benchmark costs which may be rates quoted by L2 if found reasonable.
- E. If the bidder fails to complete the work or left the work incomplete, this Additional Performance Security (APS), S.D. and EMD shall be forfeited by the CREDA and the agreement shall be terminated and bidder shall be blacklisted /debarred to participate in any tender/ activity of CREDA till further orders.
- F. Those Bidders who have accepted the L1 rate also required to submit additional performance security for allocated work.

11. REGISTRATION OF BIDDER –

Bidders should have a valid registration certificate of System Integrator in CREDA in SPV programme for FY 2020-21. Bidders who are not registered with CREDA, upon allocation of work shall register himself as system integrator of CREDA within 30 days of such allocation failing which work allocation shall stand cancelled without any further notice in this regard and allocation work shall be re-allocated to other parties as per Bid condition.

12. VALIDITY -

Full descriptive particulars and complete specifications should accompany the offer. Offers should be kept open for acceptance for at least **180 days** from the date of opening. After finalization of this Bid the approved rates shall be valid till one year from the date of award; however CREDA shall have liberty to increase or decrease this validity if needed.

13. TERMS & CONDITIONS -

- A. The terms, conditions and specifications mentioned in Bid document shall be binding on the Bidders and no condition or stipulation contrary to the conditions shall be acceptable. It may please be noted that the Bidders who do not accept terms and conditions stipulated in this Bid documents, their offers shall be liable to be rejected out-rightly without assigning any reason whatsoever.

- B. Each page of Bid document & enclosures shall be signed by the Bidder and seal affixed. All the pages of the documents issued must be submitted along with the technical offer. In case of any corrections / alterations in the Bid, the Bidder should attest the same; otherwise Bids may not be considered.
- C. Bidders are also instructed to submit their Bids in properly arranged manner (with index, proper paging and with flags on important documents). Incomplete, lose, conditional or improper arranged Bids will not be accepted.

14. CREDA RESERVES THE RIGHT -

- (i) To reject or accept any or all Bids fully or partly without assigning any reason on the grounds considered advantageous to CREDA, whether it is the lowest Bid or not.
- (ii) To split the quantities against the Bid further for the same items/work. No reason will be assigned by CREDA for this and will be binding on the Bidders.
- (iii) To increase or decrease of aggregate quantities up to 100 % as per discretion or circumstances.
- (iv) Rates approved through this Bid may be standardized for all eligible Bids to work in **year 2020-21** and shall be valid till **31-03-2022**. However CREDA reserves right to curtail or extend this period.

15. COMMUNICATIONS -

- A. All the communication between Bidder and CREDA shall be in writing. Notice sent by official letter, Fax or other Electronic means shall be effective on confirmation of the transmission. Notice sent by registered post or speed post shall be effective of delivery or at expiry of normal delivery period as under taken by Postal Service.
- B. Offers through Telegraph/Fax/Emails/Post/Courier or open offers etc. received shall be summarily rejected.

16. BID DOCUMENT FEE AND EARNEST MONEY-

- A. Each Bidder should submit Bid Document Fee and earnest money in the form of Demand Draft/Pay Order or RTGS/NEFT as mentioned in the NIT vide 15537/CREDA/HOR/See-Saw/2020-21 Dt 05.02.2021, in a separate envelope as prescribed at **point no.04 of page 06**, else they will summarily be rejected and returned. Bid Document Fee & EMD submitted in any other form e.g. **Cash/Bank Guarantee/FDR /TDR etc. shall not be accepted.**
- B. MSME unit registered for manufacturing or service of solar pumps or components in Chhattisgarh state and public sectors of government are exempted from EMD subjected to submission of valid document.

17. SUBMISSION / DISPLAY OF SAMPLES -

Bidders will have to provide samples of their cylinder, Tank, Structure, Stand Post, Taps, B.O.S. and etc. All components should be submitted for examination before **03:00 PM dated 26.02.2021** at H.O. CREDA, VIP Airport Road, Raipur. These samples shall be examined by Technical Committee of CREDA.

18. PRE-BID QUERIES -

The purpose of allowing pre-bid queries will be clarifying issues and to answer questions in any matter that can be raised at that stage. Minutes of the meeting and the responses given will be uploaded for information of bidders. Any modification of the bidding document which may become necessary as a result of pre-bid queries shall be uploaded on CREDA's website and shall be integral part of original Bid document and communicated through corrigendum.

19. TECHNICAL CRITERIA -

- A. Bidder must have valid test report/certification of equipment used in see-saw water pumping systems separately in their names for which Bidder must make offer for installation. They will have to provide copy of such test report/certification of their system. **Bidder will be debarred from price bidding for all other categories for which they have not submitted valid test report/acknowledgement.**

- B.** Bidders shall have to submit the Test certificate against Acknowledgement within 30 days of execution of agreement otherwise EMD may be forfeited and bidder may be blacklisted / debarred by CREDA. However this time limit may be further extended / reduced by CREDA if required.
- C.** The Bidder should have sufficient technically qualified and well-experienced manpower for execution of the project and after sales service of the systems. These details may be called by CREDA and in case there is any deficiency found the Bidder may be debarred.

20. FORFEITURE OF EARNEST MONEY DEPOSIT -

It should be clearly understood that in the event of Bidder failing to enter into the agreement in the prescribed format on their quoted rates and also fails to execute assigned works under any Scheme of CREDA, within stipulated time, if he is so communicated within the validity period of the offer, the full amount of earnest money will be forfeited and Bidder shall be debarred from future business with CREDA. CREDA's decision in this regard will be final and binding on the Bidders.

21. PRICE OF SUPPLY OF SEE-SAW WATER PUMPING SYSTEMS WITH INSTALLATION, COMMISSIONING AND TESTING OF SYSTEM -

- I.** The Price quoted for see-saw pumping system with installation, commissioning and testing, of Cylinder, Structure, Tanks, Pipe, Suction Pipe, Clamp, Stand post, Civil works and all other required BOS like Cables, Suitable Nut Bolts etc. with 5 years system warranty, insurance and COMC. The GST shall be paid extra as per prevailing rate (the GST regulation notification no. 24/2018-Central tax (Rate) dated 31.12.2018). Any change in GST shall be become applicable during the period of contract.
- II.** In this regard if there is any change in the composition ratio of goods and services by any Authority/ Courts, same shall be applicable.

22. ENGINEERING DOCUMENT -

Bidders will have to submit Engineering Documents with technical details, drawings, Specifications of components and make etc. to CREDA for approval, as and when asked by CREDA. Works may only be started out only after approval of the Engineering Document and their samples.

23. INSPECTIONS -

CREDA reserves right to inspect the material at Godowns / Temporary Stores before dispatch and also at works sites.

24. TAX OBLIGATIONS -

CREDA shall deduct TDS for Income Tax, applicable cess on Civil Work etc. under various acts and deposited with the appropriate authority. Costs and taxes before execution of agreement with CREDA so as to ensure tax deposition as per Government Rules accordingly.

25. JURISDICTION OF THE COURT -

Any dispute arising out of the contract shall be subject to the jurisdiction of Hon'ble High Court of Chhattisgarh.

SECTION - 2

GENERAL CONDITIONS OF CONTRACT

1. DEFINITIONS -

In writing General Conditions of Contract, the specifications and bill of quantity, the following words shall have the meanings hereby indicated, unless there is something in the subject matter or content inconsistent with the subject.

- CREDA shall mean the Chhattisgarh State Renewable Energy Development Agency represented through the Chief Engineer.
- Work shall mean any work entrusted to the Bidder as mentioned in the scope of work and Work Order.
- The "Engineer in charge" shall mean the Engineer or Engineers authorized by CREDA for the purpose of this contract. Inspecting Authority shall mean any Engineering person or personnel authorized by CREDA to supervise and inspect the erection of the **See-Saw Water pumping system**.
- "The Eligible SI/Bidder" shall mean the Bidder awarded with the contract or their successors and permitted assigns. Contract Price shall mean the sum named in or calculated in accordance with the provisions of the contract as the contract price. General Conditions shall mean the General conditions of Contract.
- "Specifications" shall mean the specifications annexed to these General Conditions of contract and shall include the schedules and drawings attached thereto or issued to the eligible SI from time to time, as well as all samples and pattern, if any,
- "Month" shall mean calendar month. "Writing" shall include any manuscript, typewritten, printed or other statement reproduced in any visible form whether under seal or written by hand.

2. CONTRACT DOCUMENT -

The term "Contract" shall mean and include the General conditions, specifications, schedules, drawings and Work Orders etc., issued against the contract schedule of price or their final general conditions, any special conditions applying to the particular contract specification and drawings and agreement to be entered into. Terms and conditions not herein defined shall have the same meaning as are assigned to them in the Indian contract Act or any other Act in vogue or by any person of common knowledge and prudence.

3. MANNER OF EXECUTION -

- A. Execution of work shall be carried out under Government Mode Scheme of CREDA in an approved manner as outlined in the technical specifications or where not outlined, in accordance with desired Specifications laid down by CREDA, to the reasonable satisfaction of the Engineer.
- B. Successful Bidder / Bidder here-in-after called the **SI** (System Integrator).
 - i) After receipt of LOI from CREDA the eligible SI shall conduct a detailed survey of site and submit site details in prescribed format after due verification and signatures of Head master of school, Sarpanch or Sachiv or concerned Local body/person and signatures of AE/EE/Officer In Charge of Concerned Department. All necessary documents and survey details shall have to be submitted in concerned District Office of CREDA in prescribed manner. SI shall also have to submit yield report of bore well / water source to be used for the system, NOC for its use and a layout plan duly consented and signed jointly by concerned person or Local body and signatures of AE/EE/Officer In Charge of Concerned Department.
 - ii) Engineer-in-Charge of District Office of CREDA shall examine these applications. After his satisfaction will forward details with his recommendations to EE of Concerned Regional Office of CREDA. Engineer-in-charge may visit the site if he/she is not satisfied with survey report.
 - iii) In case Engineer-in-Charge of District Office of CREDA finds the site not suitable for installation of See-saw pumping system, he/she will inform concerned beneficiary organisation/department accordingly and request for alternative site /necessary action.
 - iv) Executive Engineer of concerned Regional Office CREDA will decide the technical feasibility and layout plan of site. Executive Engineer may visit the site if he/she is not satisfied with survey report.

- v) After satisfaction Executive Engineer will forward the site clearance report with technical feasibility to Head Office CREDA for issuance of work orders.
- vi) HO CREDA will be final authority to approve or reject site finalisation recommended by Regional Offices.
- vii) Concerned Chief Engineer of CREDA after his satisfaction shall issue the work order to eligible SI for installation of system.
- viii) Work order will be given to the chosen System Integrator only after execution of the agreement with CREDA.
- ix) After issuance of Work Orders Executive Engineer of concerned Regional Office CREDA will finally approve site layout in writing in prescribed format.
- x) All the materials required for the installation of see-saw as per Work Order issued shall be kept at site in the custody of the SI. CREDA shall not be responsible for any loss or damage of any material during the installation.
- xi) After work is started CREDA will carry out inspections at various stages and Engineer-in-Charge of District Office of CREDA shall record the measurements in the Measurement Book issued for the said site.
- xii) After installation joint inspection will be done in presence of beneficiary, SI and CREDA and after successful commissioning of system and its approval from CREDA a JCC will be signed and the subsidy claim will be forwarded for payments as per guidelines and procedures of CREDA.

4. VARIATIONS, ADDITIONS & OMISSIONS -

CREDA shall have the right to alter, amend, omit, split or otherwise vary the quantum of work, by notice in writing to the SI. The eligible SI shall carry out such variation in accordance with the rates specified in the contract so far as they may apply and where such rates are not available; those will be mutually agreed between CREDA and the eligible SI.

5. INSPECTION -

- A. The Engineer-in-Charge or his authorized representative(s) shall be entitled at all reasonable times to inspect and supervise and test during installation and commissioning. Such inspection will not relieve the eligible SI from their obligations under this contract.
- B. Material can be inspected before dispatch or in transit by the authorized representatives of CREDA at the factory / godown at the cost of the eligible SI, if desired by CREDA.
- C. CREDA will undertake real time performance and quality test of randomly selected See-Saw Water Pumping system and components during the course of execution as per the specifications and guidelines laid by CREDA to ensure quality and performance of pump and components.

6. COMPLETION OF WORK -

Time being the essence of contract, the installation of the system shall be completed within the time schedule prescribed in the Work Order.

7. ELIGIBLE SYSTEM INTEGRATOR'S DEFAULT LIABILITY -

CREDA may by written notice of default to the eligible SI, terminate the contract in circumstances detailed hereunder -

- (a) If in the opinion of the CREDA, the eligible SI fails to complete the work within the time specified in the Work Order or within the period for which extension has been granted by CREDA to the eligible SI.
- (b) If in the opinion of CREDA, the eligible SI fails to comply with any of the provisions of this contract.
- (c) In the event of CREDA terminating the contract in whole or in part as provided in paragraph (a) above, CREDA reserves the right to engage another eligible SI or agency upon such terms and in such a manner as it may deem appropriate and the eligible SI shall be liable to CREDA for any additional costs or any losses caused to CREDA as may be required for the completion of erection of the See-Saw Water pumping system and or for penalty as defined under this Bid document until such reasonable time as may be required for the final completion of the work.
- (d) In the event CREDA does not terminate the contract as provided in paragraph (a) the eligible SI shall continue performance of the contract, in which case he shall be liable to CREDA for penalty for delay as set out in this Bid document until the work is completed.

8. **FORCE MAJEURE -**

The eligible SI shall not be liable for any penalty for delay or for failure to perform the contract for reasons of FORCE MAJEURE such as of God, acts of public, enemy, LWE problems, acts of government, cyclone, fires, floods, epidemics, quarantine restrictions, strikes, freight embargoes provided that if SI shall submit delay notice with appropriate cause of delay to the CREDA in writing within **15 days** of force majeure. CREDA shall verify the facts and may grant such extension as facts justify. Delay in supply of any accessories of system etc. by the related vendors, to whom the Bidder has placed order, shall also not be treated as force majeure.

9. **REJECTION OF WORKS -**

In the event of any of the material supplied/work done by the eligible SI is found defective in material or workmanship or otherwise not in conformity with the requirements of this contract specifications, CREDA shall either reject the material and/or work and advise the eligible SI to rectify the same. **CREDA may impose penalty for such rejection up to the 200% cost of the entire system. Habitual/repeated offenders shall be black listed/debarred to participate in the any Bid/ Activity of CREDA till further orders.** The eligible SI on receipt of such notices shall rectify or replace the defective material and rectify the work free of cost. If the eligible SI fails to do so CREDA may -

- a) At its option replace or rectify such defective materials and/or work and recover the extra cost so involved from the eligible SI plus **10%** service charges of the cost of such rectification, from the eligible SI and/ or terminate the contract for balance work/ supplies with enforcement of penalty **as stated above.**
- b) Defective materials/workmanship will not be accepted under any conditions and shall be rejected outright without compensation. The eligible SI shall be liable for any loss/damage sustained by CREDA due to defective work **with enforcement of penalty as stated above.**

10. **EXTENSION OF THE TIME -**

If the completion of installation is delayed due to any reason beyond the control of the eligible SI, the eligible SI shall without delay give notice to the CREDA in writing of his claim for an extension of time. CREDA on receipt of such notice may or may not agree to extend the contract/delivery date of the System as may be reasonable but without prejudice to other terms and conditions of the contract.

11. **MAKES OF EQUIPMENTS TO BE USED IN THE WORK -**

- (I) The Cylinder, structure, tank, pipes etc. equipment & Other BOS shall be made in India. The manufacturer has to declare the list of imported components used in the See-Saw Water pumping system.
- (II) The eligible SI has to ensure that equipment's as per Technical Requirements of guidelines of CREDA as complied with. The eligible SI has also to ensure that he will use only components of approved vendors of CREDA. The material/works for which CREDA or BSI or ISI specification is not available, engineer-in-charge of the works will examine and approve the material/works, preferably of all makes on which CREDA has report of satisfactory performance. Test certificates for all major equipment's should be submitted to the engineer-in-charge of the works before installation of the same.
- (III) Successful SI upon issue of LOI must submit Manufacture Authorization Form (MAF) From manufacture of Tanks/Structures/cylinder which it is intending to use during installation guarantee at least five year warranty of system, **no payment shall be made if he fails to do so.**
- (IV) SI Should submit warranty Agreement of **at least 5 years** for major components i.e. Cylinder, Tank, Structures, Stand Post and Special Chamber with manufacturer or distributors certified by the manufacturer before installation of Pumps, for any manufacturing defects or bad workmanship.

12. **WARRANTEE PERIOD AND POST INSTALLATION SERVICES -**

- A. The work done/material supplied by the eligible SI should be warranted for satisfactory operation and against any defect in material and workmanship at least for a period of **5 (five) years**, from the date of commissioning of the system including other works as per scope of work.
- B. The above warranty certificates shall be furnished to the CREDA for approval. Any defect noticed during this period should be rectified by the supplier free of cost upon written notice from CREDA provided such defects may be due to bad workmanship or bad materials used.
- C. The warranty period shall be extended by the period during which the plant remains non-operative due to reasons within control of the eligible SIs.

- D. This warrantee must be an unconditional onsite warrantee and the eligible SI will have to replace the defective material within **7 days** positively from the date of information given to him.
- E. Care should necessarily be taken to make the system, once the reporting of the fault/non-operational status is done, within a week. If the system is not made operational within **7 days** CREDA may rectify the same at the cost of SI and the warrantee period shall be extended for a month for the same.
- F. System Integrators shall have to establish their service stations in the allocated area and shall have to keep sufficient quantity of spares and man power to ensure proper service network for taking care of smooth functioning of system installed by them. SI shall have to give a toll free number to register complaints.

13. TERMS OF PAYMENT -

The following terms of payment shall apply for the Bid -

- A. **97%** of the eligible payment as per the Work Order after satisfactory supply, installation, commissioning & performance test of the system at site with proper handing over.
- B. Balance **3%** of the eligible payment shall be retained by CREDA as Performance Security for a period of **60 months**.

14. PENALTY FOR DELAY IN COMPLETION OF CONTRACT -

If the eligible SI fails to complete the assigned work within the schedule time specified in the Work Order or any extension granted there to, CREDA will recover from the SI as penalty a sum of **One per cent (1%)** of the system price excluding GST/Tax for every delayed system per month. For this purpose, the date of taking over shall be reckoned as the date of completion. The total penalty shall not exceed **5% (Five Per cent)** of the cost.

Review of the progress of installation of **See-Saw Water pumping system** allocated to SIs shall be done time to time by CREDA and if the progress of installation is found unsatisfactory, the allocation of entire remaining uninstalled pumps or their part of can be re-allocated to other SI as per discretion of CREDA.

15. SECURITY DEPOSIT (SD) -

- A. The Earnest Money shall be retained by CREDA as additional SD for five years after agreement is done to execute all the works referred to in the Bid documents upon the terms and conditions contained or referred to therein and to carry out such deviations as may be required by CREDA.
- B. Beside this, **3%** of the cost shall also be retained as SD during the five years of warrantee period. No interest shall be payable on the Security Deposit.
- C. Period for which EMD and SD are to be retained may be extended in case the warrantee period is extended due to non-performance of the system.

16. INSURANCE -

- A. The eligible SI shall arrange insurance coverage for the materials and system at his/beneficiary's custody for the work under execution and successful commissioning and subsequent handover to the beneficiary. The eligible SI shall take up insurance or such other measures for the manpower so as to cover the claim for damage / accident under workmen's compensation Act and other applicable State/Central laws. CREDA shall not bear any responsibility on this account.
- B. Eligible SI shall arrange for insurance coverage for complete see-saw pumping system during warrantee period i.e. for **05 years** from the date of installation. Insurance should cover for damage and theft. In case of such incidence, SI must replace the lost/damaged part within **7 days** from the date of intimation.

17. PENALTY DUE FROM THE ELIGIBLE SI -

All costs of damages and delays for which the eligible SI is liable to the CREDA will be deducted from any money due to the eligible SI including the security deposit of any project under CREDA.

18. ELIGIBLE SI'S RESPONSIBILITY -

Notwithstanding anything mentioned in the specifications of subsequent approval or acceptance of the see-saw pumping system by CREDA, if any, the ultimate responsibility for satisfactory performance of the entrusted work shall rest with the eligible SI. If in any case the eligible SI does not complete the work as per the Work Orders issued to them then CREDA may take over the task & complete the project at the risk and cost of eligible SI.

19. RESPONSIBILITY TO RECTIFY THE LOSS AND DAMAGE -

If any loss or damage occurs to the work or any part thereof or materials/plant/equipment's for incorporation therein the period for which the eligible SI is responsible for the cause thereof or from any cause whatsoever, the eligible SI shall at his own cost rectify/replace such loss or damage, so that the permanent work confirms in every respect with the provision of the contract to the satisfaction of the Engineer. The eligible SI shall also be liable for any loss or damage to the work/equipment's occasioned by him in course of any operation carried out to him during performing the contract.

20. RESPONSIBILITY TOWARDS THE WORKMAN OR OUTSIDERS –

A. The eligible SI shall have to take insurance coverage from any authorized Insurance Company against Workmen compensation due under Workmen Compensation Act and submit copy of the insurance document before issuance of Work Order.

B. The eligible SI shall ensure all safety measures during execution and repairs of the work. CREDA, will, in no case be responsible for any accident fatal or non-fatal, caused to any workman or outsider in course of transport or execution or repairs of work.

C. All the expenditure including treatment or compensation will be entirely borne by the eligible SIs. The eligible SI shall also be responsible for any claims of the workers including, labour payments PF, Accidental Insurance, Gratuity, ESI & other legal obligations.

D. CREDA shall have all rights to deduct such claims of payments from SI in case of complaints of such violations.

21. NON-ASSIGNMENTS -

The eligible bidder shall not assign or transfer the Work Orders issued as per this contract or any part thereof without the prior approval of CREDA.

If eligible bidder transfer/assigned/sublet full or any part of work allocated to him without prior permission from CREDA in writing to any third party shall be liable to debar/black listed from any Bid/Activity of CREDA till further orders.

22. CERTIFICATES NOT TO AFFECT RIGHTS OF CREDA -

The issuance of any certificate by CREDA or any extension of time granted by CREDA shall not prejudice the rights of CREDA in terms of the contract nor shall they relieve the eligible SI of his obligations for due performance of the contract.

23. SETTLEMENT OF DISPUTES THROUGH ARBITRATION -

A. Except as otherwise specifically provided in the contract, all disputes concerning questions of fact arising under the contract shall be decided by the Chief Executive Officer (CEO), CREDA provided a written appeal by the eligible SI is made to CREDA. The decision of the CEO, CREDA shall be final and binding to the all concerns.

B. Any dispute or difference including those considered as such by only of the parties arising out of or in connection with the contract shall be to the extent possible be settled amicably between the parties. If amicable settlement cannot be reached then all disputed issues shall be settled by arbitration.

24. LAWS GOVERNING CONTRACT -

The contract shall be constituted according to and subject to the Laws of India and jurisdiction of the High Court of Bilaspur, Chhattisgarh.

25. LANGUAGE AND MEASURES -

All documents pertaining to the Contract including specifications, schedules, notice correspondences, operating and maintenance instructions, drawings or any other writings shall be written in English/Hindi language. The metric system of measurement shall be used in this contract.

26. CORRESPONDENCE -

A. Any notice to the eligible SI under the terms of the contract shall be served by registered mail to the registered office of the eligible SI or by hand to the authorized local representative of the eligible SI and copy by post to the eligible SI's principal place of business.

B. Any notice to CREDA shall be served to the Chief Engineer, CREDA Raipur in the same manner.

27. SECRECY -

The eligible SI shall treat the details of the specifications and other documents as private and confidential and they shall not be reproduced without written authorization from CREDA.

28. AGREEMENT -

The successful eligible SI shall have to enter into an agreement with the CREDA in the approved contract agreement form within **10 days** of the receipt of call from CREDA.

29. **DECLARATION OF CONFLICT OF INTEREST** - The contractor hereby declares that nobody connected with or in the employment of CREDA is not/shall not ever be admitted as partner in the contract.
30. **BID EVALUATION CRITERIA** -
- A. Offers of only those parties, who are found qualified based on Eligibility Criteria and Techno-commercial Bid, will be taken into further consideration and financial bid of only those parties who are qualifying the criteria of Techno-commercial Bid will be opened.
 - B. Other things being equal, the lowest rates shall normally be preferred, but CREDA shall have rights and liberty to amend/lower the rates.
 - C. **Conditional Bids shall not be accepted.**
 - D. However CREDA shall have rights and liberty to call any /other parties to work on approved rates as and when requires in accordance with quantum of work and scheduled time limits for completion of targets.
31. **EVALUTION OF PRICE BID** -
Price bid shall be evaluated on the basis of Quoted rates. Lowest rates of system shall be considered however CREDA shall have discretionary power to amend/lower the rates.
32. **ALLOCATION OF TARGETS AND AREA OF WORK** -
- i. Lowest rate will be the total of rate of supply and Installation & Commissioning of complete system excluding the rate of COM.
 - ii. L1 Bidder will be given preference for allocation of work.
 - iii. Subsequently all other eligible bidder will be awarded with equal number of work on L1 rate; Quantity may change according to the number of sanctioned works. Further allocation shall be made on the basis of their performance subsequently. However CREDA has sole discretion to award any number of works to any eligible bidder.
 - iv. CREDA reserve rights to increase or decrease quantities to be allocated to the eligible bidder on the basis of the availability of stock with the bidder and time limits for the projects.
 - v. Allocation of works shall only be done as per availability of budget.
 - vi. Allocation can be further extended as per discretion of CREDA, in interest of expeditious work completion.
 - vii. CREDA reserves all rights for allocation of works anywhere in Chhattisgarh.
 - viii. **Review of the progress of installation of See-Saw Water pumping system allocated to SIs shall be done time to time by CREDA and if the progress of installation is found unsatisfactory, the allocation of entire remaining uninstalled pumps or their part of can be re-allocated to other SI as per discretion of CREDA.**

(Name, Signature & Seal of the SI)

SECTION-3 SCOPE OF WORK

The scope of work in brief will be as follows-

1. Survey of Sites, design, supply, installation & commissioning of See-Saw water pumping system as per design and specifications approved by CREDA, on turnkey basis. Bidder shall have to take approval of the engineering documents, Bill of Materials and samples from CREDA prior to commencement of the work. Five years unconditional onsite warrantee for manufacturing defects shall be required for each of the system after successful commissioning and proper handing over.
2. The scope of work shall also include the following:
 - 2.1 Survey of Sites, estimation of yield of bore well, Submission of site clearance certificate and yield report where the See-Saw water pumping system is to be installed. A layout plan of the site should also be submitted clearly indicating the identified location for installation of See-Saw water pumping system.
 - 2.2 Work order shall be issued only after receipt of satisfactory site clearance reports suitable for system installation.
 - 2.3 SI shall furnish all necessary information to beneficiary for See-Saw water pumping system Warrantee, DOs & Don'ts etc. so as to avoid further misunderstandings and disputes.
 - 2.4 Detailed planning of time bound smooth execution of project.
 - 2.5 Design, supply, installation & commissioning of See-Saw water pumping system as per design and specifications approved by CREDA, on turnkey basis.
 - 2.6 **To ensure safe deposit of hand pump if already exists in the designated stores of concerned Department in case of using new See-Saw water pumping system with the system. Acknowledgement should have to be submitted for the same with JCC.**
 - 2.7 Providing User Manuals and Warrantee Cards to beneficiary / CREDA.
 - 2.8 SI shall have to submit JCCs within 60 days of Installation and Commissioning of **See-Saw Water pumping system** in District Office of CREDA.
 - 2.9 Unconditional onsite warrantee for manufacturing defects for Five years faultless operation, assure inventory for maintenance.
 - 2.10 Providing Prompt Service Facilities to customers/ beneficiaries.
 - 2.11 SI must ensure safety and insurance against risk liability of all personnel associated during installation and repairs of the system.
 - 2.12 Training of at least two persons nominated by user, on the various aspects of operation and maintenance of the offered system after commissioning of the system.
 - 2.13 The eligible SI shall maintain sufficient inventory of the spares to ensure that the system can be made functional within 7 days from the communication of breakdown of the system during the warrantee period.
 - 2.14 The eligible SI shall run the system on trial basis and shall closely monitor the performance of the system before handing over the system, so that the assured water discharge can be estimated for monitoring of the performance of the system. CREDA shall examine the water discharge and ascertain if the discharge is adequate with reference to the capacity of the See-Saw Water pumping system.
 - 2.15 The eligible SI shall have to monitor the performance of the system before its handing over to the beneficiary, so that the desired water output can be assured.
 - 2.16 System Integrators shall have to establish their service stations in the allocated area and shall have to keep sufficient quantity of spares and man power to ensure proper service network for taking care of smooth functioning of **See-Saw Water pumping system** installed by them. SI shall have to give a toll free number to register complaints.
 - 2.17 Bidder should have to install only those cylinder that can be installed even in the bore well of 4 inch (100MM) Dia.
 - 2.18 For the installation of See-Saw water pumping system Bidder should have to follow Quality Assurance and Quality Control (QAQC) as per the attached Enclosure.
 - 2.19 For Quality Assurance of Civil structure work in See-Saw water pumping system, it is mandatory to submit Cube Test report from Govt. Approved test centre.
 - 2.20 During 5 years COM of the system, if water level of bore well falls near the Shutoff Head and the pump fails to operate as per designed parameters then it is the responsibility of the SI to replace the system which can ensure the output as per designed parameters. In case the SI fails to do so, CREDA shall have the right to replace the pump at the cost of SI.
 - 2.21 The system integrator must ensure the cleaning of water tank at the time of commissioning of the system thoroughly from inside and must lock the cover properly to keep the water tank secure from external agents.

- 2.22 Bidder shall also have to construct pump platform and soakage Pit as per UNICEF design and drawing for drainage of water and recharging of ground water. Proper drainage arrangement must be provided from stand post platform & hand pump platform to soakage pit to ensure cleanliness around **See-Saw Water pumping system**.
- 2.23 The system shall have to be installed by trained manpower/contractor from a recognised training centre as per guidelines of CREDA. The training certificate can be checked by the officials of CREDA at the time of visit/inspection.
- 2.24 A separate sign board must be affixed with proper clamping in the structure railing in a separate GI sheet of thickness 1.2mm. The matter for sign board must be approved by CREDA HO before installation.
3. Successful Bidder / Bidder here-in-after called the **SI** (System Integrator).
- i) After receipt of LOI from CREDA the eligible SI shall conduct a detailed survey of site and submit site details in prescribed format after due verification and signatures of Head master of school, Sarpanch or Sachiv or concerned Local body/person and signatures of AE/EE/Officer In Charge of Concerned Department. All necessary documents and survey details shall have to be submitted in concerned District Office of CREDA in prescribed manner. SI shall also have to submit yield report of bore well / water source to be used for the system , NOC for its use and a layout plan duly consented and signed jointly by concerned person or Local body and signatures of AE/EE/Officer In Charge of Concerned Department.
 - ii) Engineer-in-Charge of District Office of CREDA shall examine these applications. After his satisfaction will forward details with his recommendations to EE of Concerned Regional Office of CREDA. Engineer-in-charge may visit the site if he/she is not satisfied with survey report.
 - iii) In case Engineer-in-Charge of District Office of CREDA finds the site not suitable for installation of See-saw pumping system, he/she will inform concerned beneficiary organisation/department accordingly and request for alternative site /necessary action.
 - iv) Executive Engineer of concerned Regional Office CREDA will decide the technical feasibility and layout plan of site. Executive Engineer may visit the site if he/she is not satisfied with survey report.
 - v) After satisfaction Executive Engineer will forward the site clearance report with technical feasibility to Head Office CREDA for issuance of work orders.
 - vi) HO CREDA will be final authority to approve or reject site finalisation recommended by Regional Offices.
 - vii) Concerned Chief Engineer of CREDA after his satisfaction shall issue the work order to eligible SI for installation of system.
 - viii) Work order will be given to the chosen System Integrator only after execution of the agreement with CREDA.
 - ix) After issuance of Work Orders Executive Engineer of concerned Regional Office CREDA will finally approve site layout in writing in prescribed format.
 - x) All the materials required for the installation of see-saw as per Work Order issued shall be kept at site in the custody of the SI. CREDA shall not be responsible for any loss or damage of any material during the installation.
 - xi) After work is started CREDA will carry out inspections at various stages and Engineer-in-Charge of District Office of CREDA shall record the measurements in the Measurement Book issued for the said site.
 - xii) After installation joint inspection will be done in presence of beneficiary, SI and CREDA and after successful commissioning of system and its approval from CREDA a JCC will be signed and the subsidy claim will be forwarded for payments as per guidelines and procedures of CREDA.
 - xiii) If the bore-well is with pre-existing functional submersible pump, than the See-Saw pump with cylinder shall be separately installed in the same bore without disturbing the existing pump arrangement.

SECTION - 4

SPECIFICATION FOR SEE-SAW WATER PUMPING SYSTEM

A. MECHANICAL COMPONENTS TANK MOUNTING STRUCTURE

1. The Structure as per drawings should be installed along with the hot dipped galvanized (minimum **80 microns**) structure at site. The structure should be capable of withstanding a minimum wind load of **150 Km** per hour, after grouting and installation. The hardware (fasteners) used for installation of structure should be of suitable Stainless Steel (**SS 304**). Structure should be grouted on pedestals & Foundation as per drawings.
2. The general hardware for structure fitment should be either SS 304 or 8.8 grade.
3. The minimum gross weight of the Water tank structure & see saw play equipment should be:-

S. No	SPECIFICATION OF STRUCTURE	MINIMUM WEIGHT
1	G.I. STRUCTURE OF HEIGHT 3 MTR, 4 POLE	350 KG
2	M.S. Structure of 06 seater See-saw play equipment with base plate	270 KG

4. **Only one GI sheets of thickness 1.2mm as per drawing Section-5 shall be permitted for placing of water tank on structure.**
5. **There must be sufficient passage between railing and water tank for free movement of technician around the water tank.**
6. **The inlet and delivery pipe line must be welded in the structure to avoid damaged of pipe line or dislocation of pipe line.**
7. **See-Saw foundation Details:-**
 - i. Foundation Dimension:- L x H x B= 1x1x1 meter
 - ii. Foundation jali (Box type) L x H x B=0.9 x 0.9 x 0.9 meter
 - iii. TMT bar- Main & distribution 12 mm, total weight 55 Kg
 - iv. foundation bolt 04 nos., L x B=400x16 mm
8. S.S. cylinder shall be strictly of “India mark-2, having length approximate 1000 mm and stroke size minimum 300 mm.
9. Water lift from bore well minimum 65 meters & from ground level to overhead tank minimum 10 meter.
10. The SI/ Contractor should make arrangements to weigh the components before final installation and shall get verification from CREDA official & attach self-declare certificate along with the JCC.

B. Earthing Arrangements- No requirement of Earthing & Lightning arrester.

C. MARKING AND PARAMETERS TO BE DECLARED BY THE MANUFACTURER -

The See-Saw Water Pumping Systems shall be securely marked with the following parameters declared by the manufacturer:

- a) Manufacturer's name, logo or trade-mark;
- b) Total head, m, at the guaranteed duty point;
- c) Capacity (LPD) at guaranteed head;
- d) Operating head range, m;

D. OPERATION AND MAINTENANCE MANUAL -

An Operation and Maintenance Manual in Hindi, should be provided with the pumping system. It should also have clear instructions about DO's and DONT's and on regular maintenance and Trouble Shooting of the pumping system. Helpline number and Name and address of the Service Centre and contact number of authorized representative to be contacted in case of failure or complaint should also be provided. A warranty card for the system equipment should also be provided to the beneficiary.

Raw material test certificates (MTC) of all types of raw material used in See-Saw Water Pumping Systems as per appropriate IS code should be submitted along with dispatch documents.

E. Overhead water storage tank specification

Rotational Moulded Polyethylene Water Storage Tanks Specification: ISI marked Rotational Moulded Polyethylene Water Storage Tank conforming to IS:12701-1996 with amendment. no 1 . The water storage tank should be as per the IS 12701: 1996 standards and must be able to withstand the stormy weather conditions. The tank material should be in such a way that it should not change the quality of water with increase of temperature. A hole of suitable internal diameter must be provided at the top of the tank for the purpose of inspection and entry into the tank.

1. Bidder shall be required to furnish satisfactory type test certificate from government laboratory, as per IS:12701/96(Reaffirmed-2006)Edition2.2 for double layer tanks, for one size (5KL)at the time of first inspection.
 2. Bidder is required to produce documents/invoices/manufacturers test certificate from O.E.Ms representing the material used in moulding, to the concerned inspectorate at the time of inspection for the lot.
 3. Bidder/Manufacturer Shall be registered with NSIC or DGS&D to IS:12701:96 (Reaffirmed 2006) Edition 2.2 specifically indicating the sizes for double layer tanks on or before tender opening.
 4. Bidder/manufacturer shall submit valid BIS licence specifically indicating the sizes for double layer tanks along with their tender.
- The complete Indian standards for overhead water storage tank are stated as under.

IS 12701 : 1996

Indian Standard

ROTATIONAL MOULDED POLYETHYLENE WATER STORAGE TANKS — SPECIFICATION

(First Revision)

1 SCOPE

1.1 This standard covers the requirements of materials, dimensions construction, shape, workmanship, performance requirements and inspection and testing of rotational moulded polyethylene water storage tanks with a nominal service temperature from +1°C to +50°C

1.1.1 These tanks are not meant for underground applications.

1.2 This standard is applicable only to water storage tanks subjected to the following two conditions:

- a) Own hydrostatic head of water, and
- b) Tank with uniform flat base support.

1.3 This standard does not cover mobile water tanks and horizontal cylindrical water tanks.

2 REFERENCES

2.1 The Indian Standards listed in Annex A are necessary adjuncts to this standard.

3 TERMINOLOGY

3.0 For the purpose of this standard the following definitions shall apply.

3.1 Rotational Moulded Water Storage Tank

A tank moulded from polyethylene powder by the process of rotational moulding.

3.2 Net Capacity

Net capacity shall be net volume of water contained between the lowest level of the inlet and lowest specified level.

3.3 Gross Capacity

The total enclosed volume of the tank including any space which may not be capable of being filled with water.

3.4 Mould Parting Line

A circumferential line visible only on external surface of the tank corresponding to a parting joint of the mould required for rotational moulding (*see Fig. 1*).

3.5 Overall Height

The height of the finished empty tank at its highest point including the top rim of the man-hole and lid of the tank (*see Fig. 1*).

3.6 Effective Height

The height of the finished empty tank from its base to the point where overflow connection is provided for the purpose of limiting water storage capacity (*see Fig. 1*).

3.7 Overall Diameter

The maximum diameter of finished empty tank measured at its base as the mean of two measurements of diameters including wall thickness of the tank and avoiding the mould parting line (*see Fig. 1*).

3.8 Rim Height

The perpendicular distance from the highest point of the top rim of the man-hole to the nearest point of the shoulder of the finished empty tank (*see Fig. 1*). Rim can be provided above the tank or within the tank.

3.9 Man-Hole/Hand-Hole

A hole of suitable internal diameter provided at the top of the tank, for the purpose of inspection of internal surface and entry into the tank.

3.10 Internal Diameter of Man-Hole/Hand-Hole

The internal diameter of the rim of the man-hole measured as the mean of two perpendicular diameters (*see Fig. 1*).

4 MATERIALS

4.1 The material of construction of tank, lid and fittings which come in contact with water shall be such that it does not impart any taste, colour or odour to water, nor have any toxic effect, and it shall not contaminate water thereby making it unpotable.

4.2 Polyethylene resin to be used for the manufacture of water tanks should be of rotational moulded grade and duly stabilized with anti-oxidants. The anti-oxidants used, not exceeding 0.3% by mass of finished resin, should be physiologically harmless and should be selected from the list given in IS 10141 : 1982. In addition, the material shall also meet the requirements given in 4.2.1 to 4.2.4.

4.2.1 The density of resin (base material) at 23°C when tested in accordance with IS 7328 : 1992 shall be within 932 to 943 kg/m³.

IS 12701 : 1996

4.2.2 The melt flow rate (MFR) of the resin when tested under the test condition D (temperature 190°C and nominal load of 2.16 kg) and in accordance with IS 2530 : 1963 shall be within 2.0 to 6.0 g/10 minutes.

4.2.3 The water tanks meant for out door use shall be manufactured from carbon black compounded polyethylene. The carbon black content and carbon dispersion test shall be carried out in accordance with the procedure described in IS 2530 : 1963 and shall meet the following requirements:

a) The percentage of carbon black content in the material shall be within 2.0 and 3.0, and

b) The dispersion of carbon black shall be satisfactory.

4.3 The addition of not more than 10 percent of the manufacturers own reworked material resulting from the manufacture of tanks only according to this standard is permissible. No other reworked or recycled waste material from any other source or filler shall be used in the manufacture of tanks.

5 TYPES AND FEATURES

5.1 Cylindrical Vertical Tank (Fig. 1)

The dimensions, net and gross capacities and weight of the tank shall be as given in Table 1.

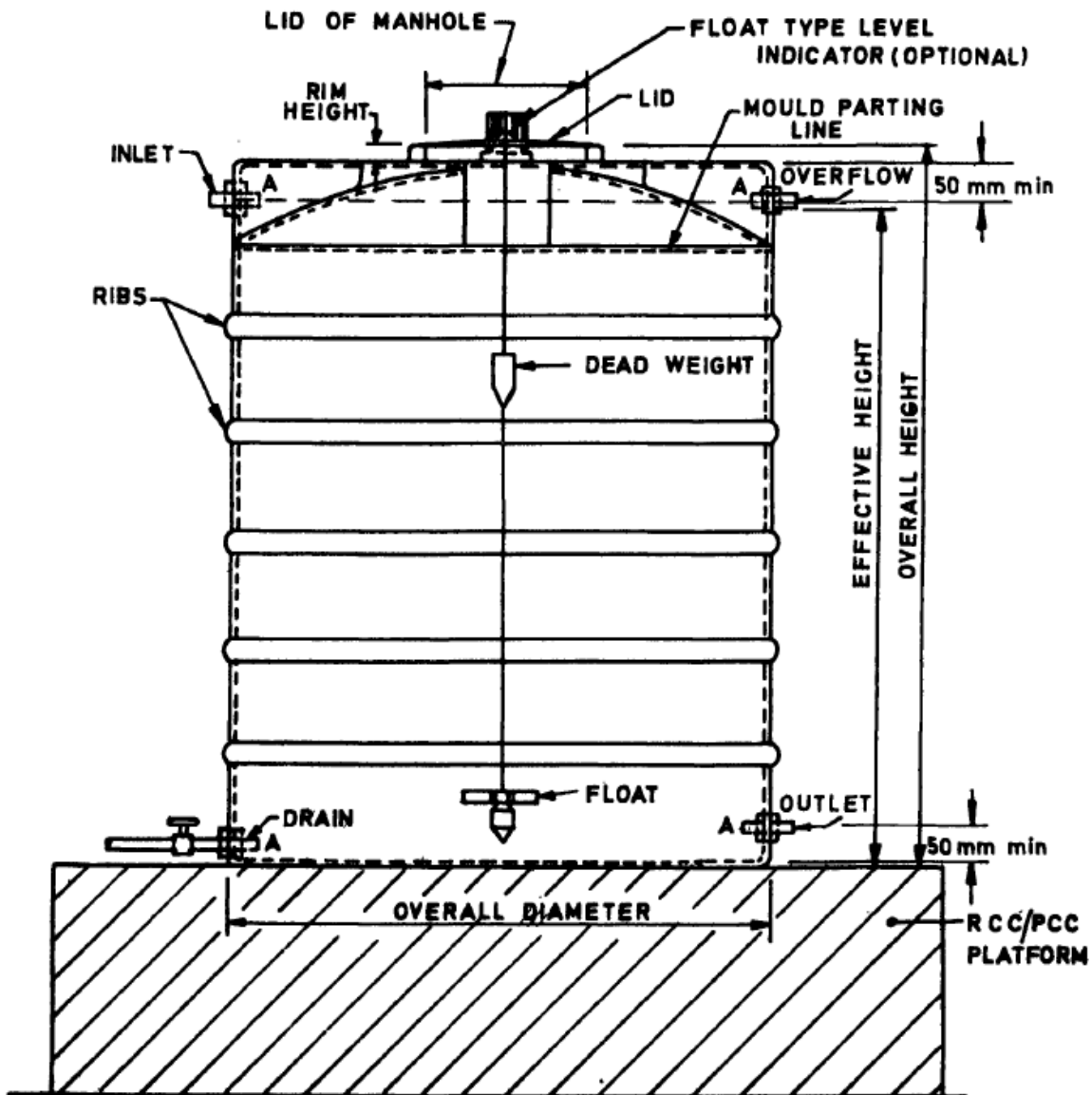

NOTE — A 25 mm wide band shall be painted around the tank at the inlet/overflow level and outlet level. Centre line of the band shall be 50 mm minimum from top/inner bottom of the tank.

A — Male threaded G.I. brass or PVC connections.

FIG. 1 TYPICAL DETAILS OF CYLINDRICAL VERTICAL TANK

IS 12701 : 1996

Table 1 Dimensions of Cylindrical Vertical Tank
(Clause 5.1)

Sl No.	Minimum Net Capacity Up to Effective Height (l)	Overall Dimeter Range (mm) (3)	Overall Height Range (mm) (4)	Minimum Internal Dia of Man-Hole/ Hand-Hole (mm) (5)	Minimum Wall and Bottom Thickness (mm) (6)	Minimum Weight of tank (Without Lid) (kg) (7)
(1)	(2)	(3)	(4)	(5)	(6)	(7)
i)	200	650 - 850	490 - 690	265	3.0	7.8
ii)	300	650 - 850	700 - 900	265	3.0	9.0
iii)	400	700 - 980	700 - 950	265	3.5	15.0
iv)	500	800 - 1 140	625 - 1 025	370	4.0	18.0
v)	700	900 - 1 140	800 - 1 100	370	4.4	23.0
vi)	1 000	1 000 - 1 200	1 050 - 1 350	370	4.5	33.0
vii)	1 500	1 080 - 1 450	1 150 - 1 590	370	4.5	47.0
viii)	1 700	1 300 - 1 500	1 260 - 1 650	370	4.5	54.0
ix)	2 000	1 365 - 1 500	1 400 - 1 700	450	5.4	64.0
x)	2 500	1 380 - 1 610	1 400 - 1 810	450	7.7	81.0
xi)	3 000	1 410 - 1 800	1 640 - 2 150	450	8.1	96.0
xii)	4 000	1 450 - 1 920	1 750 - 2 400	450	10.4	147.0
xiii)	5 000	1 800 - 2 110	1 800 - 2 100	450	10.7	180.0
xiv)	6 000	1 800 - 2 200	2 065 - 2 800	450	10.7	205.0
xv)	7 500	1 890 - 2 250	2 100 - 2 930	450	10.7	239.0
xvi)	10 000	1 900 - 2 680	2 400 - 3 740	450	11.5	319.0
xvii)	15 000	2 100 - 2 680	3 100 - 4 000	450	11.5	408.0
xviii)	20 000	2 100 - 3 150	3 190 - 5 000	450	13.2	566.0

NOTE — The gross capacity of the tanks shall be at least 5 percent in excess of the minimum net capacity.

5.2 Rectangular Loft Tank (Fig. 2)

The dimensions, net and gross capacities and weight of the tank shall be as given in Table 2.

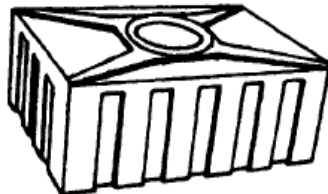

FIG. 2 RECTANGULAR LOFT TANK

5.3 A flat area may be provided on the top of the cylindrical vertical tanks for workers to stand before entering the tank.

5.4 Wall Thickness

Owing to limitations of rotational moulding process, the wall thickness of the water storage tank at bottom, top and cylindrical sides at the bottom and top edges where the shape of tank changes is usually found to be much greater than the wall thickness at other surfaces. For cylindrical vertical tanks the wall thickness upto the effective height of the tank shall not be less than the values given in Table 1 and the wall thickness above the effective height of the tank shall be not less than 75 per cent of the values given

Table 2 Dimensions of Rectangular Loft Tanks
(Clause 5.2)

Sl No.	Minimum Net Capacity	Overall Length	Overall Width	Overall Height	Minimum Internal Dia of Hand Hole	Minimum Wall Thickness (Measured on Rectangular Vertical Port and Bottom Thickness)	Minimum Weight of Tank (Without Lid)
(1)	(2)	(3)	(4)	(5)	(6)	(7)	(8)
i)	150	620 - 820	620 - 820	285 - 485	300	2.75	6.6
ii)	200	930 - 1 130	620 - 820	285 - 485	300	2.75	7.7
iii)	300	995 - 1 200	620 - 820	285 - 485	300	2.75	11.0
iv)	400	1 150 - 1 350	855 - 1 150	335 - 535	300	2.75	13.0
v)	500	1 150 - 1 500	900 - 1 250	335 - 535	300	2.75	17.5

NOTE — The gross capacity of the tanks shall be at least 5 percent in excess of the minimum net capacity.

IS 12701 : 1996

new size and shape of water tank is introduced. However, if no change is envisaged, at least one sample of any size shall be put to 'Type Tests' once in a year. Tests for suitability of tank material as specified in 4 and overall migration as specified in 7.6 shall be taken as type tests.

9 MAN-HOLE HAND-HOLE LIDS

9.1 Materials

Man-hole hand-hole lids shall be moulded from polyolefins of minimum thickness 3mm and shall have sufficient ribs to provide adequate stiffness. It shall be stabilized with 2 to 3 percent of carbon black having satisfactory dispersions. The carbon black content and carbon dispersion test shall be carried out in accordance with IS 2530:1963

9.2 The lid shall fit securely over the top rim of the tank and it shall rest evenly on it in order to prevent the ingress of foreign matter such as insects, mosquitoes or dust through the top of the tank. The lid shall also be provided with suitable locking arrangement.

9.2.1 To test the lid being fit securely to the manhole, no clearance in it should permit a 1.6 mm diameter wire to pass through.

10 MARKING

10.1 All the water storage tanks shall be marked with the following information:

- a) Manufacturer's name, initials or recognised trade mark;
- b) Net capacity in litres;
- c) Lot or Batch number, and year of manufacture; and
- d) 'For indoor use only', for tanks meant for indoor use.

10.2 In additions to the marking by painting, the manufacturers name or trade mark and net capacity of the tank shall be moulded on the external surface of the tank during manufacture.

10.3 BIS Certifications Marking

The tanks may also be marked with Standard Mark.

10.3.1 The use of the Standard Mark is governed by the provisions of the *Bureau of Indian Standards Act, 1986* and the Rules and Regulations made there under. Details of conditions under which a licence for the use of the standard mark may be granted to the manufactures or producers may be obtained from the Bureau of Indian Standards.

ANNEX A

(Clause 2.1)

IS No.	Title	IS No.	Title
554 : 1985	Dimensions for pipe threads where pressure-tight joints are required on threads (<i>third revision</i>)	9845 : 1986	Methods of analysis for the determination of specific and/ or overall migration of constituents of plastic materials and articles intended to come into contact with foodstuffs (<i>first revision</i>)
1879 : 1987	Malleable cast iron pipe fittings (<i>second revision</i>)	10141 : 1982	Positive list of constituents of polyethylene in contact with foodstuffs, pharmaceuticals and drinking water
2530 : 1963	Methods of test for polyethylene moulding materials and poly-ethylene compounds	10146 : 1982	Polyethylene for its safe use in contact with foodstuffs, pharmaceuticals and drinking water
4905 : 1968	Methods for random sampling	13360	Plastics — Methods of testing :
7328 : 1992	High density polyethylene materials for moulding and extrusion	(Part 5/Sec 7) : 1995	Part 5 Mechanical properties, Section 7 Determination of flexural properties
8543 (Part 4/Sec 1) : 1984	Methods of testing plastics : Part 4 Short term mechanical properties, Section 1 Determination of tensile properties		

means of 100 kg load applied on the horizontal surface provided for a man to stand before entering the tank. After removal of the load the test specimen shall be inspected for deformation or crack on the surface and after 4 hours of the removal of the load the flat surface shall return to normal position.

type tests are intended to prove the suitability and performance of water tank of a new composition, a new technique, new shape or modified wall thickness. Such tests need necessarily be done, before undertaking mass production when a change is made in polymer composition or method of manufacture or when a

IS 12701 : 1996

ANNEX B

(Clauses 7.1.1 and 7.1.2)

METHOD OF DEFORMATION TEST

B-1 METHOD 1, FOR CYLINDRICAL VERTICAL TANKS

B-1.1 The water tank shall be placed on a flat level base. A circumferential measurement shall be made parallel to the base at a distance of one third the effective height. The tank shall be filled upto the effective height at a minimum rate of 23 l/min with water at temperature of not less than 15°C.

B-1.2 A continuous film of polythelene shall be floated over the whole of the surface of the water in the tank to prevent evaporation.

B-1.3 The tank and water shall be maintained at temperature not less than 15°C and after 3 days a circumferential measurement shall be made at the previously determined level.

The difference between the two circumferential measurement shall be expressed as a percentage of the original circumferential measurements.

B-2 METHOD 2, FOR RECTANGULAR LOFT TANK

B-2.1 The rectangular tanks shall be placed on a flat level base. The internal length and width of the tank shall be measured on the centre lines, as shown in Fig. 3 at the centre of effective height.

B-2.2 The tank shall be filled upto the effective height at a minimum rate of 23 litres/min with water at a temperature not less than 15°C. The lid shall be closed after filling the loft tank.

B-2.3 The tank and water shall be maintained at a temperature of not less than 15°C and after 7 days measurements of length and width shall be made at a previously determined centre lines.

B-2.4 The deformation in each direction shall be calculated as follows:

$$D_L = \frac{W_2 - W_1}{2L_1} \times 100$$

$$D_w = \frac{L_2 - L_1}{2W_1} \times 100$$

Where

D_L = deformation of the longer side,

D_w = deformation of the shorter side,

W_1 = width at the start of test,

W_2 = width at the end of the test,

L_1 = length at the start of test, and

L_2 = length at the end of test.

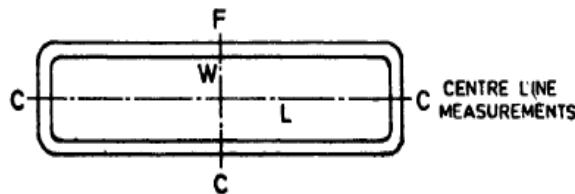

FIG. 3

ANNEX C

(Clause 7.2)

C-1 METHOD FOR IMPACT RESISTANCE TEST FOR WATER TANK

C-1.1 The water tank shall be inverted and the base of tank shall be struck with a 25 mm diameter hemispherically ended striker of mass 2.5 kg falling freely from a height of 3.0 metre.

C-1.2 The striker shall be so arranged as to hit the base at its mid-point. Three other impacts shall be made, which shall be as close to the edge or corners of the base as is practical. The shape of the striker shall be such that only the surface of the specified hemisphere comes into contact with the tank under the initial blow.

ANNEX E
(Foreword)

RECOMMENDATIONS FOR INSTALLATION AND FITTING OF TANKS

E-1 Vent pipe/overflow pipe is provided near the top with mosquito and insect proof cap.

E-2 The flat base of cylindrical vertical or rectangular water storage tanks should be fully supported over its whole bottom area by a durable, rigid, flat and level platform sufficiently strong to withstand without deflection the weight of the tank when filled fully with the water. In case, the tank is placed on a suitable M. S. platform then it is essential that the latter is free from sharp edges, corners or surface projections and shall be corrosion resistant.

E-3 Where required the tanks shall be suitably anchored. The tanks may also be provided with clamping devices.

E-4 The pipelines, valves and other fittings should be supported in such a manner that it is aligned properly so as not to produce any distortion in the water tank where the fitting is fixed.

E-5 The checknuts of the threaded connection should be placed after placing rubber gaskets and should not be overtightened. Under no circumstances should jointing compounds or putty be employed in contact with the polyethylene water tanks. PTFE (poly-tetra-fluoroethylene) unsintered tape may be wrapped around the threaded portion of the valves and connections to act as a sealant.

E-6 Circular holes drilled for fixing threaded connections should have a clean edge free from notches. Holes can be drilled with a high speed steel hole saw cutter. Scratching or scoring the wall should not be done for setting out holes.

E-7 Where the section of water tank has a change in profile which is accomplished with a radius, it is essential that the outer extremities of the threaded connections are clear of this radius.

E-8 The water storage tank should not be installed in close proximity to heaters or other direct sources of heat.

E-9 FITTINGS

E-9.1 For providing inlet, outlet and other connections, usually full threaded G.I. brass connections are used which shall not produce any kind of harmful effect on potable water. A typical threaded connections is illustrated in Fig 4. Flat surface may preferably be provided to fix outlet pipes at appropriate locations. The design of threaded connections fixed with the water storage tank may be similar to that shown in Fig 4. The different sizes of threaded connections required to be fixed for different capacities of water storage tanks may be according to Table 6.

E-9.1.1 The overflow pipes should be provided with non-corrodible mosquito-proof device of maximum clearance not more than 1.6 mm.

Table 6 Sizes of Threaded Connections
(Clause E-9.1)

Sl No.	Capacity of Water Storage Tank	Nominal Bore Size of Threaded Connection (mm)
i)	Up to 750	12.5
ii)	Above 750 and up to 2 000	25
iii)	Above 2 000 and up to 4 000	40
iv)	Above 4 000 and up to 10 000	50
v)	Above 10 000	75

E-9.2 The dimensions of male and female threads of G.I. PVC/brass full threaded connections and other fittings like elbow, tee, bend, coupling, nipple, etc, shall be conforming to IS 554 : 1985. The sizes and other dimensions of the fittings, such as centre-to-face, face-to-face and centre-to-centre shall conform to IS 1879 : 1987. Manufacturers shall provide instructions for fittings.

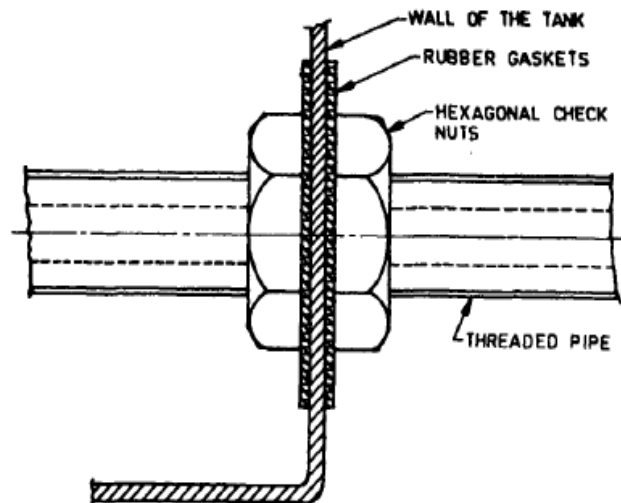

FIG. 4 THREADED CONNECTION

F. TESTS TO BE PERFORMED ON SEE-SAW WATER PUMPING STRUCTURE FOR WATER PUMPING SYSTEM -

1. For ascertaining proper welding of structure part following should be referred -
 - a. Weld wire grade should be of grade **(ER 70 S -6)**
 - b. D.P. Test (Pin Hole / Crack) **(IS822)**
2. For ascertaining hot dip galvanizing of fabricated structure following should be referred -
 - a. Min coating required should be as per IS4759.
 - b. Testing of galvanized material.
 - i. Peerce Test (CuSO₄ Dip Test) **(IS2633)**
 - ii. Mass of Zinc **(IS 6745)**
 - iii. Adhesion Test **(IS2629)**

G. WATER SUPPLY SYSTEM & WIRE ROPE

MS pipe 63 mm size shall be used from S.S. cylinder to Outlet/Output delivery or water tank. Only G. I. pipe of 50/32/25 mm size shall be used for over ground connection such as inlet, outlet and over flow connection of overhead tank and to distribution line connected to four mouth hot dip galvanised Common stand post with stainless steel self-closing (304 grades) taps at a height 800mm. After testing of the pipe distributions and stand posts the trenches to be filled up with excavated earth up to a depth of 30 cm watering and riming and making good to the damages of the road as per pre road condition (WBM/CC/Bituminous).

H. CIVIL SUPPLY / INSTALLATION:-

1. Civil supply / installation essential for erection of Overhead Tank Structure as per local site conditions and soil formation and drawing specified in the tender.
2. Civil supply / installation essential for erection and skirting of Stand Post - 2mtr x2mtr with proper drainage.
3. Civil construction of Soak pit of 1m dia X 1m depth

I. GALVANIZED TAP STAND :-

1. Tap Stand should be hot dip galvanized with having platform of 2 mtr x 2mtr with proper drainage up to 3 mtr as per the drawing specified in tender.
2. Stand should consist of 4nos. of 20mm stainless steel lift-cock type taps at height min. 800 mm.

SECTION-5

Complete drawing of 3Mtr Staging, 2KL See-Saw water pumping structure & Civil Works

A. Layout plan for See-Saw water pumping system

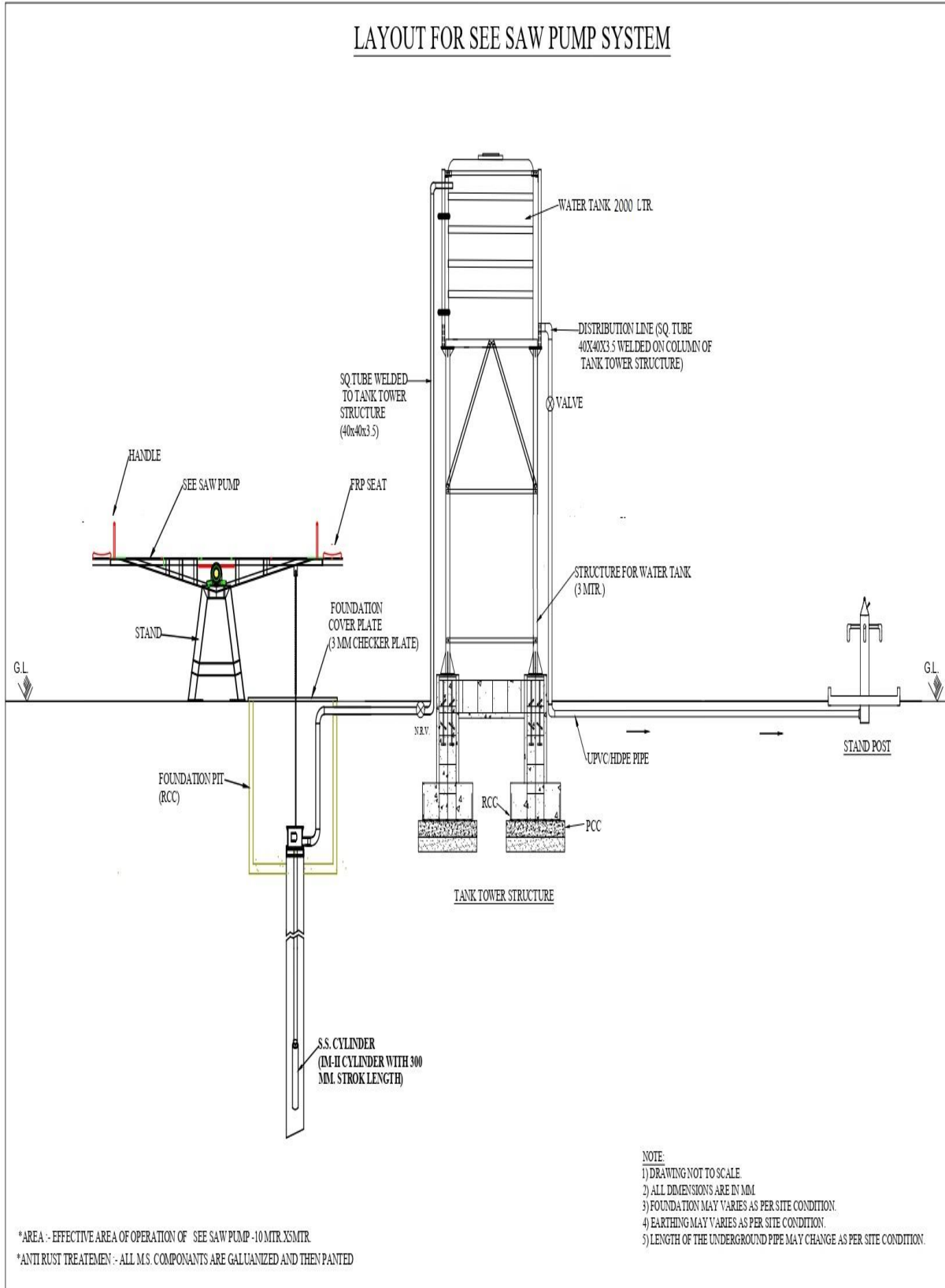

B. Water tank structure

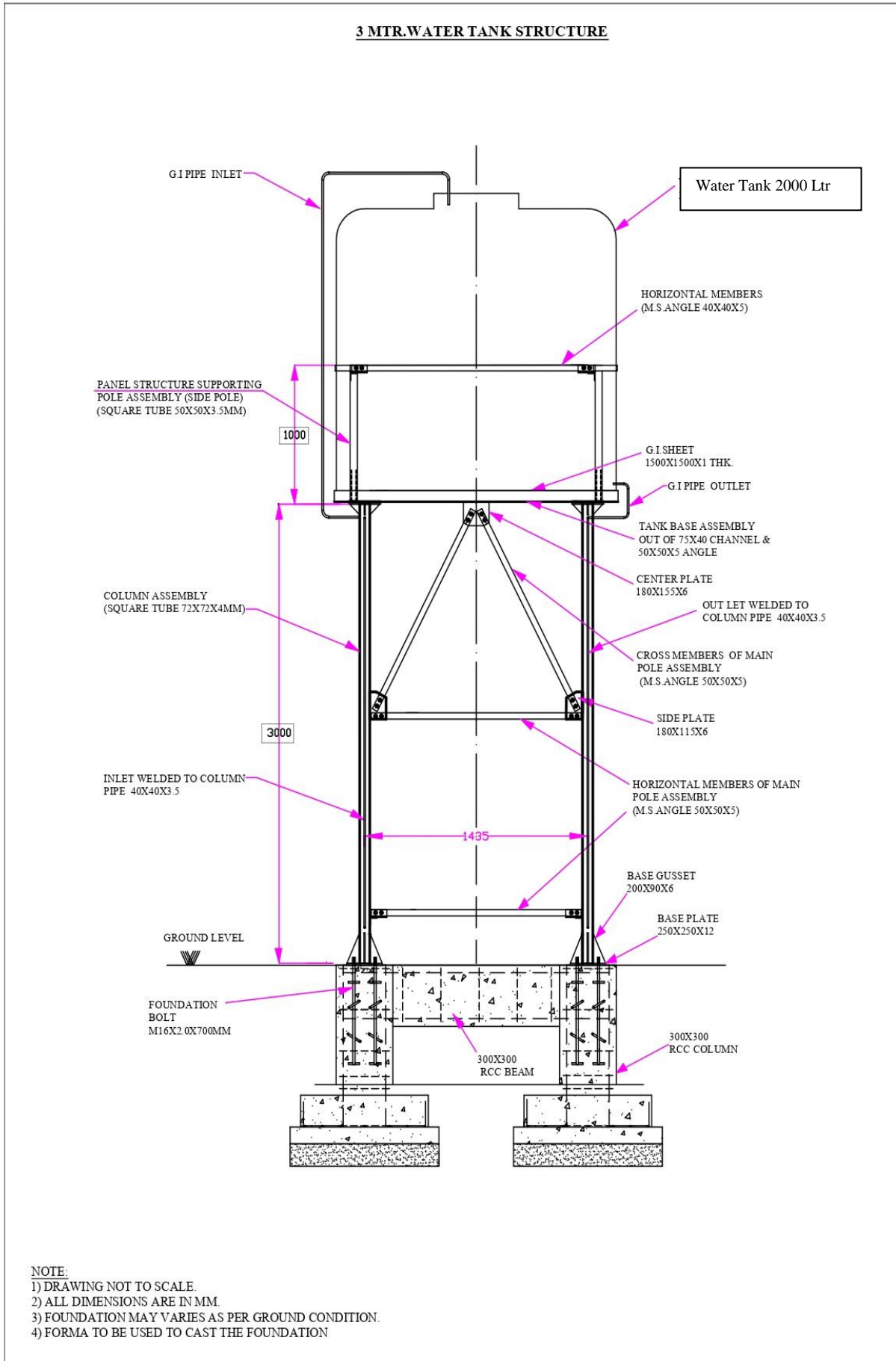

C. Structure foundation

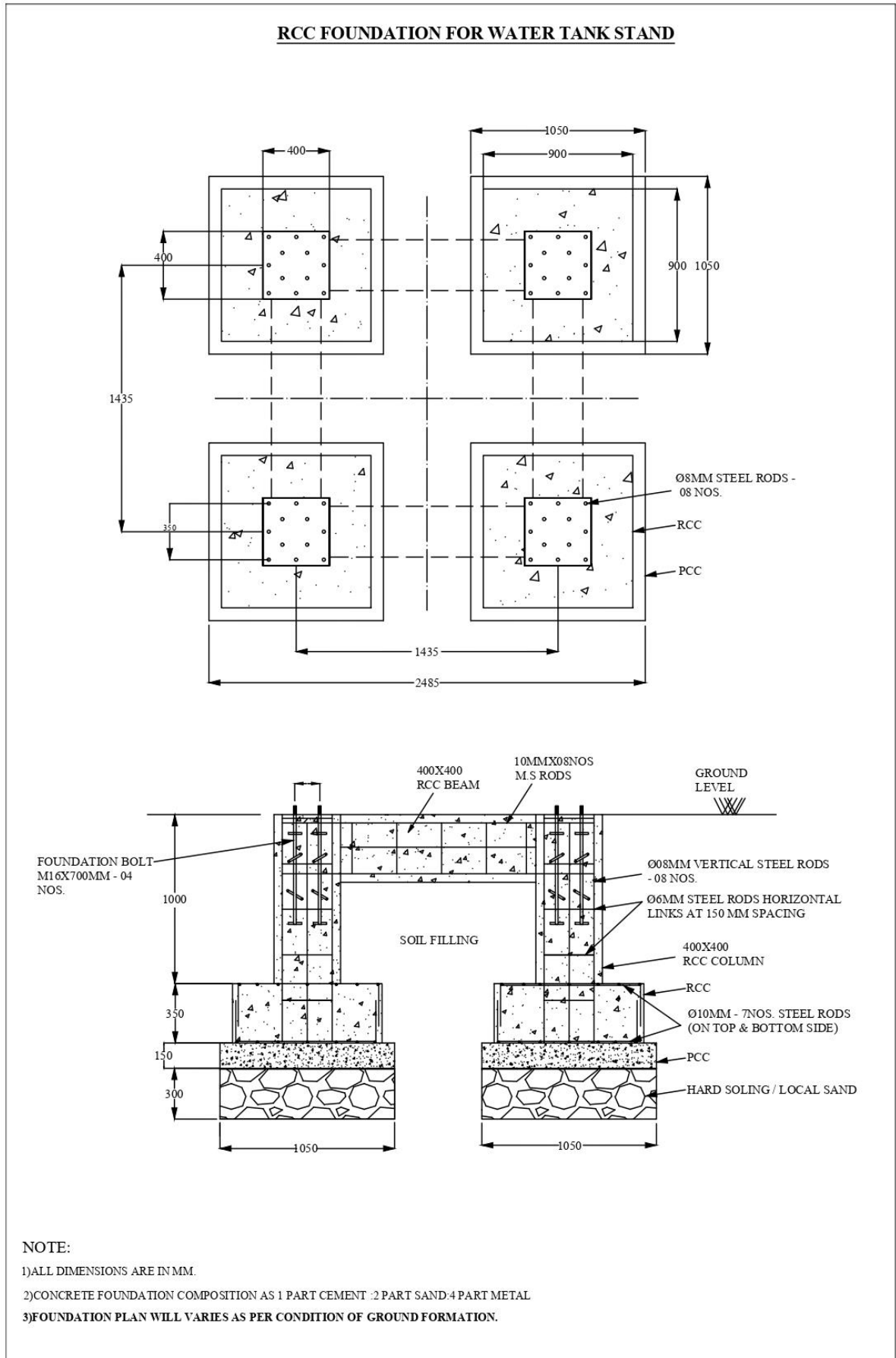

D. LAYOUT FOR SEE-SAW PUMP PLAY SYSTEM (6 Seater)

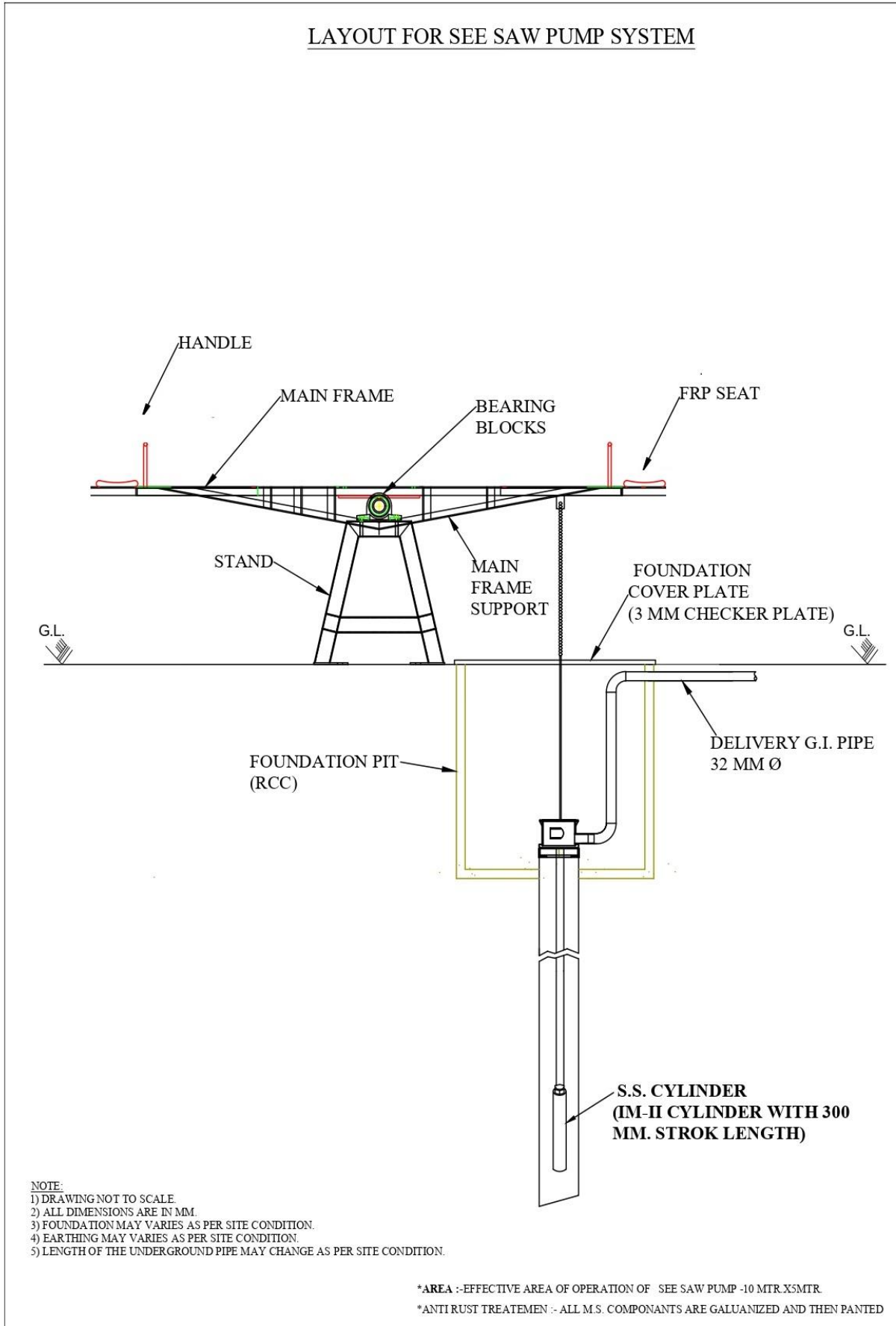

E. (A) See-Saw pump assembly-(06 Seater)

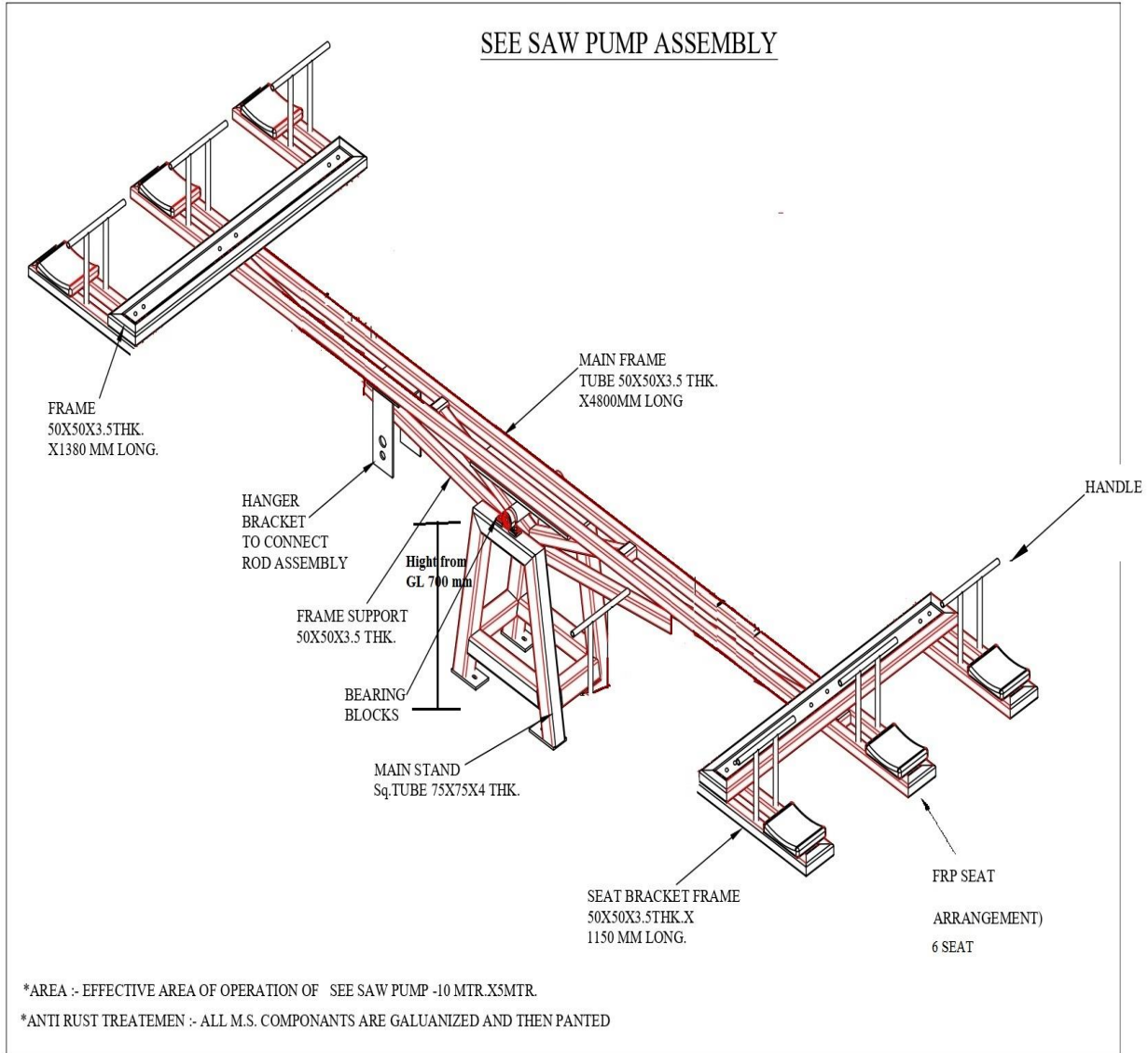

F. Layout for Stand post

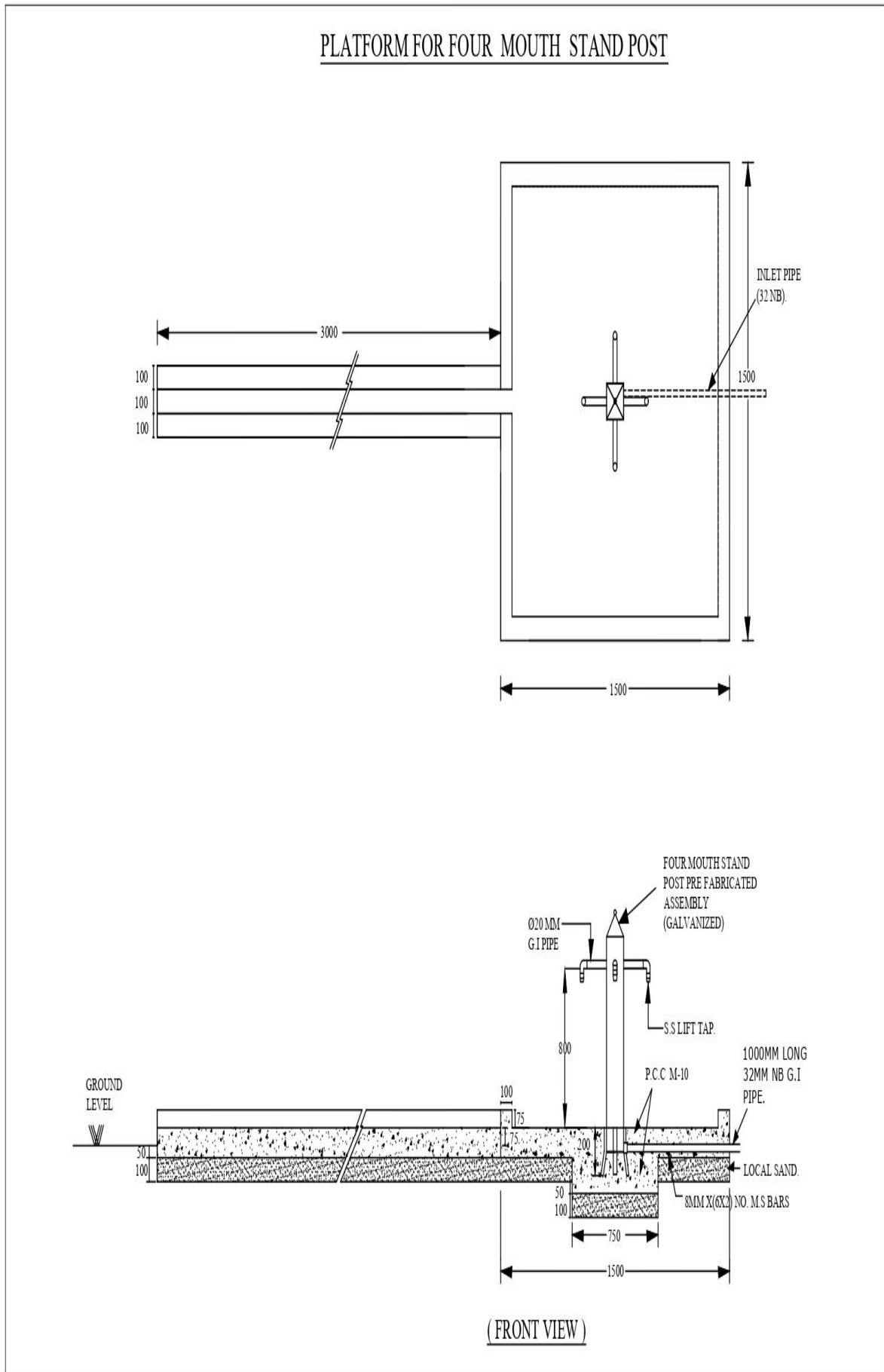

G. Complete drawing of Stand Post with all civil works

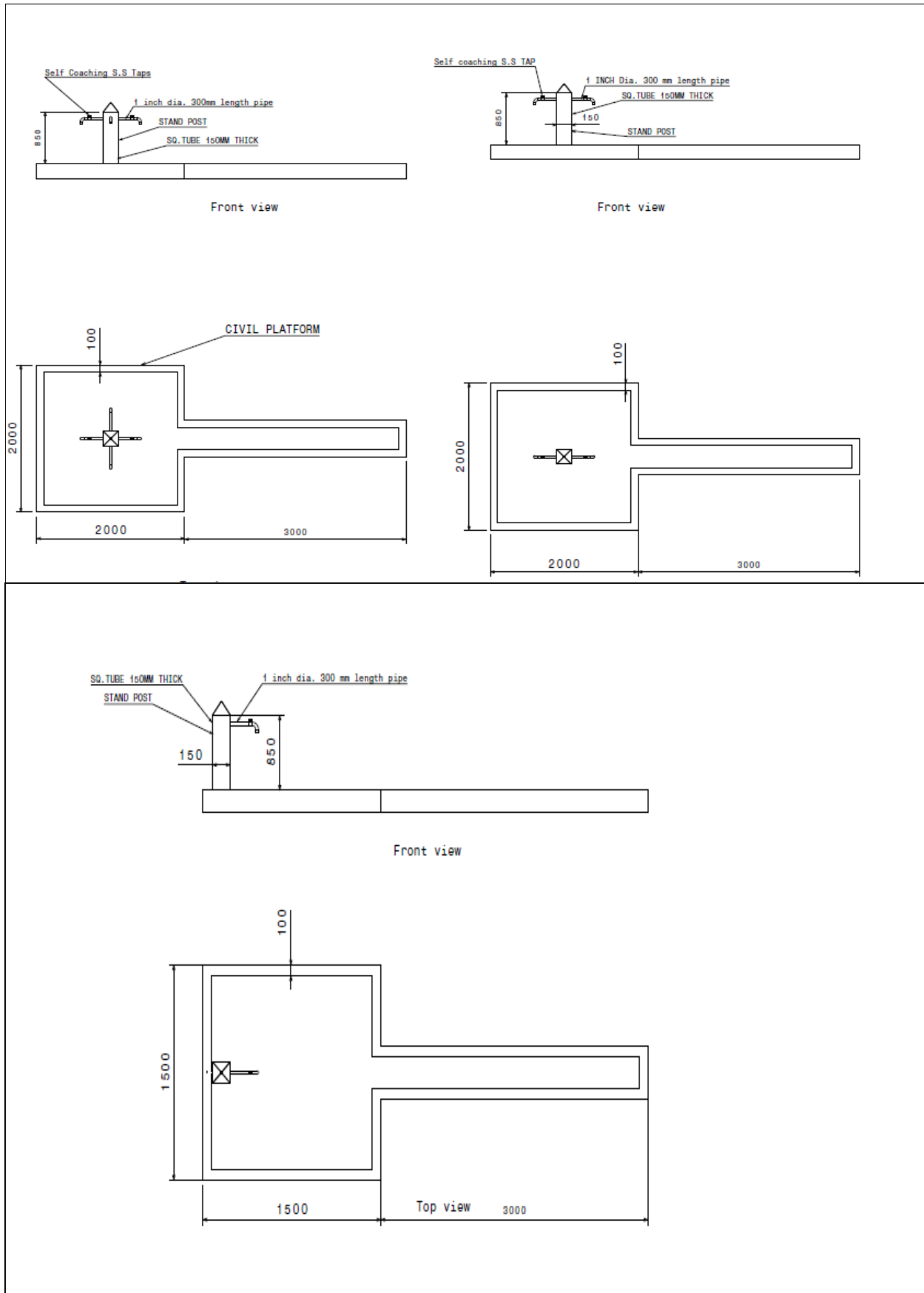

H. DRAWING OF SOAKAGE PIT

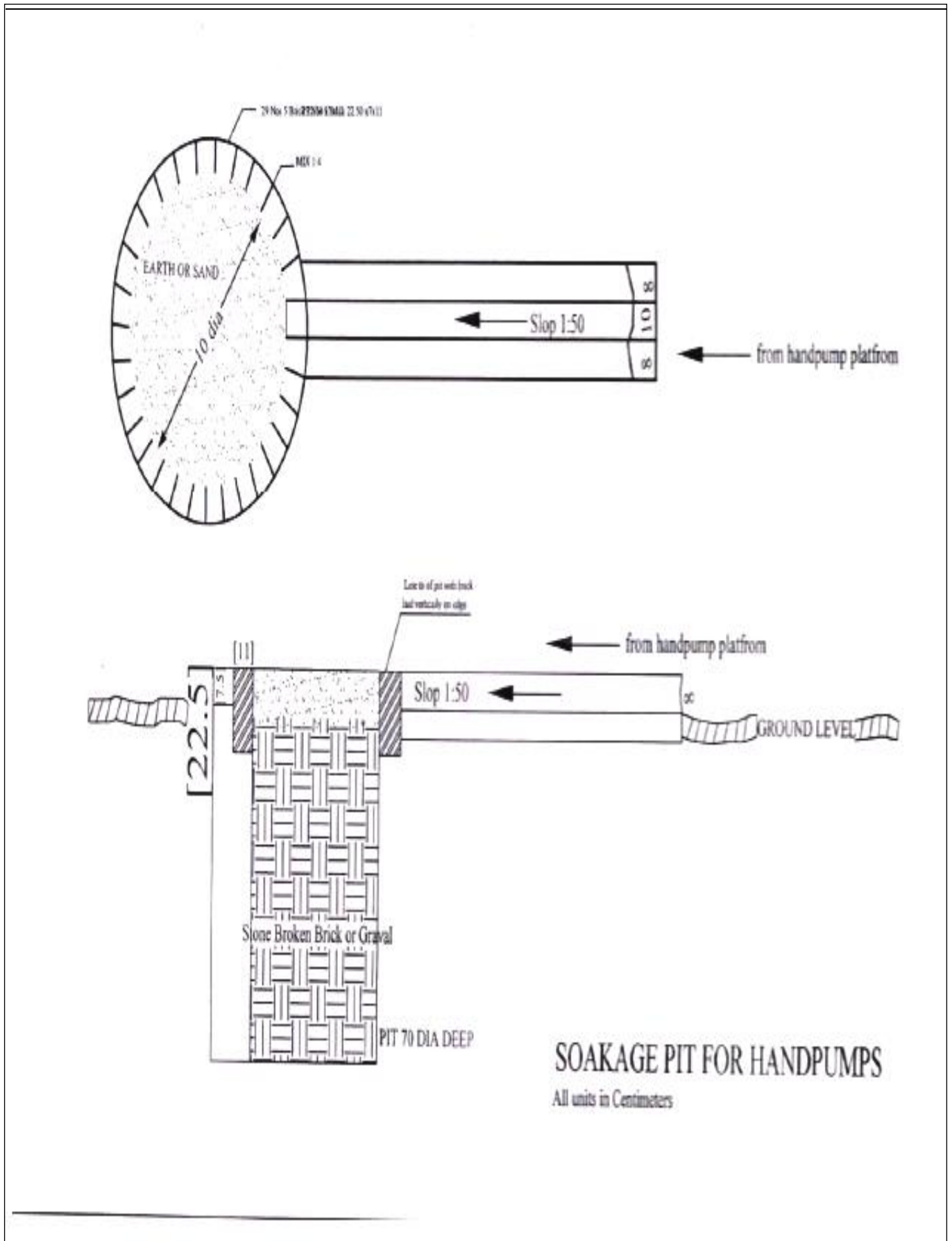

SECTION-6

INSTALLATION & COMMISSIONING OF SYSTEM

1. Survey Works

- For excavation, the marking of the block needs to be done as per the approved block drawing. Visual/Physical inspection is to be undertaken as per drawings
- Foundation marking needs to be undertaken as per approved construction drawings.

2. Excavation works

- Nature and type of soil needs to be ascertained visually before excavation
- Initial ground level needs to be marked before start of the excavation as per the approved construction drawings
- Final Shape and dimension of the excavation along with final excavation level needs to be measured as per the technical specification in the construction drawing.

3. Compaction of filled soil

- Soil quality and water level needs to be visually inspected for each site before PCC bedding. Soil compactness needs to be visually checked for each site.

4. Construction Materials

- Cement needs to be procured from ISI certified brand with minimum grade of cement of **OPC 43 Grade**. Cement storage needs to be done in weather tight covered storage platform and stacking of cement bags needs to be proper. Random inspection to be undertaken.
- Coarse aggregate particle size needs to be **less than 20mm**
- Fine aggregate/MS sand particle size needs to be around 5 mm with mix of foreign materials.
- **One Cube test by every contractor** needs to be tested for compression strength and basis results, compaction ratio and grade of material will be established, which will be followed throughout the project. If required, basis site requirements, separate cube test can be undertaken to establish site-specific compaction ratio/material mix.

5. Reinforcement Steel and Placement

- Reinforcement steel needs to be free of cracks, surface flaws and lamination as per technical specification under IS: 1786, IS:432 and IS:1852
- Bending of Bars and tolerance levels needs to be established as per IS:2502
- Spacing of bars, reinforcement cage placement is to be visually inspected as per IS:2502 and approved construction drawings
- Reinforcement bar centre line alignment, depth and verticality needs to be reviewed as per approved foundation drawings.

6. Concrete

- Concrete trial mix and design mix is to be tested in lab as per IS:456, SP:23, IS:10256. One cube test per contractor is to be tested for crushing strength as per IS:456
- Dimension and visual examination for finished concrete with minimum curing time of 7 days is to be undertaken. The cured concrete block should be free from foreign and oversized aggregates.

SECTION-7

Price Bid (For supply, installation, Commissioning & Testing of System)

Schedule of Rates for **See-Saw Water pumping system**

(bidding as per Specifications & Scope of Work of No...../CREDA/HOR/2020-21 Dated: 05.02.2021)

Rates for design, Supply, Survey, Installation and Commissioning of **See-Saw Water pumping system** anywhere in the State of Chhattisgarh as per tender specifications.

SN	Capacity of See-Saw Water Pumping System	Rate (Excluding GST)	Rates of 05 years COM in Rs. (Excluding GST)	TOTAL AMOUNT in RS. (Ex.GST)
1.	Survey, supply, design, manufacturing, & installation, testing, Insurance of the See-Saw Water Pumping System including civil Foundation with See-saw 06 seater playing Equipment (M.S.), With following item:- 1.) 01 no. 2000 liter HDPE water tank (kept on existing building if available), all suitable accessories like- inlet and outlet GI pipeline, cylinder assembly, connecting rod. 2.) Stand post with 04 nos. self-locking Taps. 3.) Soakage pit, all suitable accessories other required BOS and with five years warrantee.			
2	Supply, installation, testing of 03 Mtr. G.I. Structure (if building not available for 2KL water tank) (Minimum Weight 350 kg) Including civil foundation work with all suitable accessories other required BOS with five years warrantee.			

Above rates are FOR anywhere in the State of Chhattisgarh inclusive of roadworthy packing, loading, unloading, all types of incidental expenses, 5 years warrantee, insurance and COM as mentioned in the Bid document. Above rates applicable for CREDA Specifications stated in Bid document.

According to GST notification no. 24 /2018-Central Tax (Rate) Dated 31.12.2018 GST Rate will be applicable under composite supply, installation, testing basis (As per applicable) at the time of billing. No other cost will be claimed other than above quotes price & the applicable GST.

Note: In this regard if there is any change in the composition ratio of goods and services by any Authority/ Courts, same shall be applicable.

Name of Company:

Name of Authorized Signatory:

Signature & Seal of the Authorized Signatory:

Date:

DRAFT AGREEMENT

CONTRACT AGREEMENT BETWEEN Chief Engineer Chhattisgarh State Renewable Energy Development Agency (CREDA) Raipur AND M/s..... Represented by THIS CONTRACT AGREEMENT against Bid No. 15537 /CREDA/HOR/ See-Saw 2020-21, Dated: 05.02.2021 (also referred to as “Service Contract”) is made on theth day of 2021.

BETWEEN

(1) Chief Engineer Chhattisgarh State Renewable Energy Development Agency (CREDA) Raipur a society incorporated under the laws Society Registration Act 1973 , (1973 , Sr. No. 44) (with amendment from time to time) and having its Registered Office at VIP Road Near Energy Education Park, Village- Fundhar, Raipur and (hereinafter called “The Employer” and also referred to as “CREDA”)

And

(2) Represented bya company incorporated under the laws of Companies Act 1956/2013/ Partnership firm/ Proprietorship firm/Consortium (as applicable, with amendment from time to time) and having its Principal place of business at and Registered Office at.....hereinafter called “The Contractor” and also referred to as “.....”

Whereas the contractor has offered to enter into contract with the said CREDA for the Survey, design, Supply of See-Saw water pumping System and for installation, commissioning and comprehensive operation & maintenance of See-Saw water pumping System with 5 years Warranty.

Wide Tender No. 15537/CREDA/HOR/See-Saw/2020-21 Dated: 05.02.2021 on the terms and conditions herein contained and the rates approved by the CREDA (Letter No. dated annexed here to) have been duly accepted and whereas the necessary security deposit shall be furnished in accordance with the provisions of the Bid document and whereas no interest will be claimed on the security deposits.

Now these presents witness and it is hereby agreed and declared by and between parties to these presents as follows -

- 1) The Contractor shall, during the period of this contract, that is to say from to or completion thereof, until this Contract shall be determined by such notice as is hereinafter mentioned, safely carryout, by means of labours employed at his own expenses and by means of tools, implements and equipment etc. to be supplied by him to his labour at his own expenses, for installation of “**See-Saw water pumping systems**” as described in Bid documents. (annexed to the agreement).
- 2) The NIT (Notice Inviting Bid), Corrigendum to NIT, Notices, Bid documents (Qualifying, Technical and Financial), approved rates annexed hereto and such other additional particulars, undertaking, instructions, general conditions of contract, Scope of work, Technical specifications of See-Saw Water Pumping system and Annexure therein, engineering documents, detailed specifications of BOS & drawings, so far they relate to the Tender No.15537/CREDA/HOR/See-Saw/2020-21 Dated: 05.02.2021as may be found requisite to be given during execution of the work shall be deemed and taken to be an integral part of the contract and shall also be deemed to be included in the expression "The Agreement or "The Contract "wherever herein used.
- 3) The contractor shall also supply the requisite number of workmen with means & materials as well as tools, appliances, machines, implements, vehicles for transportation, cartage etc. required for the proper execution of work within the time prescribed in the work orders and /or as per the Bid conditions.
- 4) The Engineer in Charge or his authorized representative (s) shall be entitled at all reasonable times to inspect and supervise and test during installation and commissioning. Such inspection will not relieve the eligible SI from their obligations under this contract.
- 5) Material can be inspected before dispatch or in transit by the authorized representatives of CREDA at the factory at the cost of the eligible SI, if desired by CREDA. CREDA reserves right to inspect the material at Godowns / Temporary Stores before dispatch and also at works sites.

- 6) CREDA shall deduct TDS for Income Tax, applicable cess on Civil Work etc. under various acts and deposited with the appropriate authority. Costs and taxes before execution of agreement with CREDA so as to ensure tax deposition as per Government Rules accordingly.
- 7) **ELIGIBLE SYSTEM INTEGRATOR'S DEFAULT LIABILITY -**
CREDA may by written notice of default to the eligible SI, terminate the contract in circumstances detailed hereunder -
- (a) If in the opinion of the CREDA, the eligible SI fails to complete the work within the time specified in the Work Order or within the period for which extension has been granted by CREDA to the eligible SI.
 - (b) If in the opinion of CREDA, the eligible SI fails to comply with any of the provisions of this contract.
 - (c) In the event of CREDA terminating the contract in whole or in part as provided in paragraph (a) above, CREDA reserves the right to engage another eligible SI or agency upon such terms and in such a manner as it may deem appropriate and the eligible SI shall be liable to CREDA for any additional costs or any losses caused to CREDA as may be required for the completion of erection of the System and or for penalty as defined under this Bid document until such reasonable time as may be required for the final completion of the work.
 - (d) In the event CREDA does not terminate the contract as provided in paragraph (a) the eligible SI shall continue performance of the contract, in which case he shall be liable to CREDA for penalty for delay as set out in this Bid document until the work is completed.
- 8) **FORCE MAJEURE -**
The eligible SI shall not be liable for any penalty for delay or for failure to perform the contract for reasons of FORCE MAJEURE such as of God, acts of public, enemy, LWE problems, acts of government, cyclone, fires, floods, epidemics, quarantine restrictions, strikes, freight embargoes provided that if SI shall submit delay notice with appropriate cause of delay to the CREDA in writing within **15 days** of force majeure. CREDA shall verify the facts and may grant such extension as facts justify. Delay in supply of any accessories of system etc. by the related vendors, to whom the Bidder has placed order, shall also not be treated as force majeure.
- 9) **REJECTION OF WORKS -**
In the event of any of the material supplied/work done by the eligible SI is found defective in material or workman ship or otherwise not in conformity with the requirements of this contract specifications, CREDA shall either reject the material and/or work and advise the eligible SI to rectify the same. CREDA may impose penalty for such rejection up to the 200% cost of the entire system. Habitual/repeated offenders shall be black listed/debarred to participate in the any Bid/ Activity of CREDA till further orders. The eligible SI on receipt of such notices shall rectify or replace the defective material and rectify the work free of cost. If the eligible SI fails to do so CREDA may -
- a) At its option replace or rectify such defective materials and/or work and recover the extra cost so involved from the eligible SI plus **15%** service charges of the cost of such rectification, from the eligible SI and/ or terminate the contract for balance work/ supplies with enforcement of penalty as stated above.
 - b) Defective materials/workmanship will not be accepted under any conditions and shall be rejected outright without compensation. The eligible SI shall be liable for any loss/damage sustained by CREDA due to defective work **with enforcement of penalty as stated above.**
- 10) **EXTENSION OF THE TIME -**
If the completion of installation is delayed due to any reason beyond the control of the eligible SI, the eligible SI shall without delay give notice to the CREDA in writing of his claim for an extension of time. CREDA on receipt of such notice may or may not agree to extend the contract/delivery date of the **See-Saw Water pumping system** as may be reasonable but without prejudice to other terms and conditions of the contract.

11) PENALTY FOR DELAY IN COMPLETION OF CONTRACT -

If the eligible SI fails to complete the assigned work within the schedule time specified in the Work Order or any extension granted there to, CREDA will recover from the SI as penalty a sum of **One per cent (1%)** of the system price for every delayed system per month. For this purpose, the date of taking over shall be reckoned as the date of completion. The total penalty shall not exceed **5% (Five Per cent)** of the cost.

Review of the progress of installation of System allocated to SIs shall be done time to time by CREDA and if the progress of installation is found unsatisfactory, the allocation of entire remaining uninstalled System or their part of can be re-allocated to other SI as per discretion of CREDA.

12) PENALTY DUE FROM THE ELIGIBLE SI -

All costs of damages and delays for which the eligible SI is liable to the CREDA will be deducted from any money due to the eligible SI including the security deposit of any project under CREDA.

13) ELIGIBLE SI'S RESPONSIBILITY -

Notwithstanding anything mentioned in the specifications of subsequent approval or acceptance of the See-Saw Water pumping system by CREDA, if any, the ultimate responsibility for satisfactory performance of the entrusted work shall rest with the eligible SI. If in any case the eligible SI does not complete the work as per the Work Orders issued to them then CREDA may take over the task & complete the project at the risk and cost of eligible SI.

14) RESPONSIBILITY TO RECTIFY THE LOSS AND DAMAGE -

If any loss or damage occurs to the work or any part thereof or materials/plant/equipment's for incorporation therein the period for which the eligible SI is responsible for the cause thereof or from any cause whatsoever, the eligible SI shall at his own cost rectify/replace such loss or damage, so that the permanent work confirms in every respect with the provision of the contract to the satisfaction of the Engineer. The eligible SI shall also be liable for any loss or damage to the work/equipment's occasioned by him in course of any operation carried out to him during performing the contract.

15) RESPONSIBILITY TOWARDS THE WORKMAN OR OUTSIDERS -

- The eligible SI shall have to take insurance coverage from any authorized Insurance Company against Workmen compensation due under Workmen Compensation Act and submit copy of the insurance document before issuance of Work Order.
- The eligible SI shall ensure all safety measures during execution and repairs of the work. CREDA, will, in no case be responsible for any accident fatal or non-fatal, caused to any workman or outsider in course of transport or execution or repairs of work.
- All the expenditure including treatment or compensation will be entirely borne by the eligible SIs. The eligible SI shall also be responsible for any claims of the workers including PF, Gratuity, ESI & other legal obligations.
- SI shall have to submit JCCs within **60 days** after Installation and Commissioning of **See-Saw Water pumping system** in District Office of CREDA.

16) Contractor shall provide 05 years warranty in installed system from the date of commissioning as per the terms & conditions prescribed in the Bid No.15537/CREDA/HOR/See-Saw/2020-21 dated: 05.02.2021.

17) DECLARATION OF CONFLICT OF INTEREST - The contractor hereby declares that nobody connected with or in the employment of **CREDA** is not/shall not ever be admitted as partner in the contract.

18) (a) The contractor shall arrange insurance coverage for the materials and **See-Saw Water pumping system** at his/beneficiary's custody for the work under execution and successful commissioning and subsequent handover to the beneficiary. The contractor shall take up insurance or such other measures for the manpower so as to cover the claim for damage arising under workmen's compensation Act and other applicable State/ Central laws. CREDA shall not bear any responsibility on this account.

- (b) Contractor shall arrange for insurance coverage for See-Saw Water pumping system during COMC period i.e. for 05 years from the date of installation. Insurance should cover for damage and theft. In case of such incidence, SI must replace the lost/damaged part within 7 days.
- 19) The contractor shall abide by the terms and conditions, rules, guidelines, construction practices, safety precautions etc. stipulated in the Bid document including any correspondence between the contractor and the **CREDA** having bearing on execution of work and payments of work to be done under the contract.
- 20) The contractor shall be responsible to follow all the laws including Workmen Compensation Act and all other laws in force & shall be responsible for all the obligations towards labour including EPF, ESI, etc.
- 21) All the taxes deductible at source as per Acts in vogue shall be recovered by **CREDA** and deposited with the appropriate authorities
- 22) Contractor agrees to abide by any decision/instruction passed by the appropriate authority under Anti-profiteering rules notified by the state/central government under GST act.
- 23) Any dispute arising out of the contract shall be subject to the jurisdiction of Hon'ble High Court of Chhattisgarh.

"Herewith everything and anything contained in Tender No.15537/CREDA/HOR/See-Saw/2020-21 Dated: 05.02.2021 is part of this agreement which has been dully signed by both bidder and authorised signatory of CREDA".

In witness whereof the parties present today has hereby entered into agreement.

Signed & sealed on behalf of the above

Named contractor

Signed on behalf of CREDA

Name:

Name: **Rajiv Khare**

Designation:

Designation: **Chief Engineer**

Witness:

1. Name:-.....

2. Name:-.....

Address:-.....

Address:-.....

.....

.....

SECTION-8**Benchmark cost of See-Saw Water Pumping System**

SN	Capacity of See-Saw Water Pumping System	Benchmark Rate in Rs. (Excluding GST)	Benchmark Rates of 05 years COM in Rs. (Excluding GST)	Benchmark TOTAL AMOUNT in RS. (Ex.GST)
1.	Survey, supply, design, manufacturing, & installation, testing, Insurance of the See-Saw Water Pumping System including civil Foundation with See-saw 06 seater playing Equipment, With following item:- 1.) 01 no. 2000 litre HDPE water tank (kept on existing building if available), all suitable accessories like- inlet and outlet GI pipeline, cylinder assembly, connecting rod. 2.) Stand post platform and Stand post with 04 nos. self-locking Taps. 3.) Soakage pit, all suitable accessories other required BOS and with five years warrantee.	1,96,521/-	29,148/-	2,25,669/-
2	Supply, installation, testing of 03 Mtr. TMS Structure (if building not available for 2KL water tank) (Minimum Weight 350 kg) Including civil foundation work with all suitable accessories other required BOS with five years warrantee.	74,475/-	-	74,475/-
Total Amount ₹		2,70,996/-	29,148/-	3,00,144/-

Above rates are FOR anywhere in the State of Chhattisgarh inclusive of roadworthy packing, loading, unloading, all types of incidental expenses, 5 years warrantee, insurance and COM as mentioned in the Bid document. Above rates applicable for CREDA Specifications stated in Bid document.

According to GST notification no. 24/2018-Central Tax (Rate) Dated 31.12.2018 GST Rate will be applicable under composite supply, installation, testing basis (As per applicable) at the time of billing. No other cost will be claimed other than above quotes price & the applicable GST.

Note: In this regard if there is any change in the composition ratio of goods and services by any Authority/ Courts, same shall be applicable.

SCHEDULE - I

PART 'A': GENERAL INFORMATION

(Strike off whichever is not applicable. Separate sheets should be used, wherever necessary)

- | | | | |
|------------|---|---|----------------------|
| 01. | Name & Address of the Bidder | : | |
| 02. | Name & Address of the firm/Company etc. | : | |
| | a) Registered office | : | |
| | b) Factory/works address | : | |
| | c) Fax Nos. | : | |
| | d) Telephone / Mobile Nos. | : | |
| | e) Email id | : | |
| 03. | Confirm whether Bidder is Manufacturer | : | Yes/No |
| 04. | Only manufacturer to give following particulars | | |
| | a) Address of factory | : | |
| | b) Year of starting manufacture | : | |
| | c) Whether same/similar materials
Manufactured earlier
(if yes, give reference) | : | |
| | d) Yearly/monthly production capacity | : | |
| | e) Maximum yearly production
Achieved so far | : | |
| 05. | Whether the firm is SSI Unit of
Chhattisgarh State: | : | Yes/No |
| | a) If yes, write registration No. | : | |
| | b) Whether documentary evidence
Regarding registration enclosed | : | |
| | c) Items for registration | : | |
| | d) Period of registration | : | |
| | d) Whether latest copy Competency/
Certificate furnished | : | Yes/No |
| 06. | Whether the firm is 100% owned by | | |
| | a) State Government | : | Yes/No |
| | b) Central Government | : | Yes/No |
| | If yes, Notification/certificate issued from
The competent authority to this effect is
Enclosed | : | Yes/No |
| 07. | a) Whether the bidder is old participant
with CREDA | : | Yes/No |
| | b) If yes, whether documentary
Evidence is enclosed. | : | Yes/No |
| 08. | Any other information that bidder may like
to give in order to highlight his bid | : | If yes, give details |

PLACE :

SIGNATURE OF BIDDER

NAME IN FULL

DATE :

DESIGNATION/STATUS

FIRM/COMPANY SEAL

SCHEDULE - II

PART 'B' : COMMERCIAL INFORMATION

(Strike off, whichever is not applicable. Separate sheets should be used. Wherever necessary)

- 01. i) Earnest Money Details : Bank draft/Bankers cheque payable to "CREDA", Raipur
- ii) Amount of E.M.D. & full details : `
- iii) If exempted, state whether the bidder i / Fully Owned State/Central Govt. Unit : SSI Unit of C.G.
- iv) Reference of documentary evidence regarding exemption enclosed. : Yes/No
- 02. Whether the offer is valid for 6 months from the date of opening of commercial/technical bid. : Yes/No
- 03. Rate of Sales Tax on the date of bid (exclusive in the rate quoted) :
- 04. **DISCOUNT:**
 - a) Whether any rebate/discount is offered. : Yes/No
 - b) If yes, whether the rebate is unconditional/conditional Rate/amount of rebate/discount : Yes/No
 - c) If conditional State condition : Yes/No
- 05. **PAYMENT TERMS:** Whether CREDA's terms of payment is acceptable to Bidder : Yes/No
- 06. **COMPLETION PERIOD OF WORK:** Whether Bidder is agreeing for completion period of work as Specified in the Bid : Yes/No
- 07. **PENALTY CLAUSE:** Whether agreeable to CREDA's Penalty Clause : Yes/No
- 08. Whether agreeable to CREDA's clause of warrantee period : Yes/No
- 09. **SECURITY DEPOSIT:** Whether Security Deposit clause is understood : Yes/No
- 10. Indicate State, Central Sales Tax Registration Number State : Yes/No
Central:
(Please Note that in case of non-registration with Commercial Tax, Department Purchase Tax as admissible shall be deducted by the Purchaser from the Bills of the supplier)
- 11. Please mention whether rates offered are applicable for part quantities. : Yes/No

PLACE:

SIGNATURE OF BIDDER

DATE:

NAME IN FULL

DESIGNATION/STATUS

FIRM/COMPANY SEAL

SCHEDULE - III

PART 'C' : TECHNICAL INFORMATION

(Strike off whichever is not applicable. Separate sheets should be used. Wherever necessary)

- | | | |
|------------|--|------------------------------------|
| 01. | Whether material offered is exactly as per technical specification | : Yes/No |
| 02. | Whether the copies of completion certificate received during last 3 years from other State Nodal Agency or from other Organization for Solar pumping systems (if yes, give details) enclosed. | : Yes/No |
| 03. | Whether pamphlets/technical details literatures along with drawing etc. furnished with the offer | : Yes/No
(if yes, give details) |
| 04. | Whether the Bidder agrees to furnish material test certificates in respect of chemical composition and physical properties from Govt./ Govt. approved lab with each batch of supplies. | : Yes/No |
| 05. | Whether the Bidder has furnished details of manufacturing equipments and short history of plant | : Yes/No
(if yes, give details) |
| 06. | Whether details of manufacturing process furnished with offer. | : Yes/No
(if yes, give details) |
| 07. | a) Whether all testing facilities are available.
If so, give details and in case of non-availability of facilities indicate approved lab available in surrounding areas where tests are proposed to be conducted. | : Yes/No |

PLACE

SIGNATURE OF BIDDER

DATE

NAME IN FULL

DESIGNATION/STATUS

FIRM/COMPANY

SEAL

SCHEDULE - IV
TECHNICAL DEVIATIONS

From,
Bidder Name & Address -

To,
The CE,
CREDA, HO,
Raipur

Sub – Technical Deviations.

Dear Sir,

The technical deviations & variations to the specifications stipulated in the Bid, for the item quoted are as under -

Sl.No.	Condition of Bid	Clause No. of Bid document	Page No. document	Statement of deviations and variations
--------	---------------------	----------------------------------	----------------------	--

-

-

2. Except aforesaid deviations, the entire order, if placed, on us shall be executed in accordance with your specifications and other conditions. Variation/deviations etc. if found, elsewhere in our offer should not be given any considerations while finalizing the Bid.

PLACE

SIGNATURE OF BIDDER

DATE

NAME IN FULL

DESIGNATION/STATUS

FIRM/COMPANY SEAL

NOTE - Continuation sheet of like size & format may be used as per bidder's requirements and shall be annexed to this schedule.

SCHEDULE - V

PAST EXPERIENCE

From :

Bidder's Name & Address -

To,

The CE,

CREDA, HO,

Raipur

Sub – Performance/Past Experience.

Dear Sir,

We furnish herewith the record of our performance and experience as follows -

-

Sl.No.	Purchaser's Name & Address	Order No. Date	Ordered Quantity	Qty. supplied (Nos.)	Value of Order

-					

-

<p>PLACE</p> <p>DATE</p>	<p>SIGNATURE OF BIDDER</p> <p>NAME IN FULL</p> <p>DESIGNATION/STATUS</p> <p>FIRM/COMPANY SEAL</p>
--------------------------	--

NOTE - Photocopy of the completion certificate received from other State Agencies/Govt. Undertakings etc. should be enclosed.

SCHEDULE-VI

(EXPERIENCE CERTIFICATE ON THE OFFICIAL LETTER HEAD OF CONCERNED GOVERNMENT DEPARTMENT WITH SEAL AND SIGN BY AUTHORIZED SIGNATORY)

Ref. No.....

Date.....

CERTIFICATE OF COMPLETION

This is to certify that **Name of Bidder, Address of Registered Office** has successfully completed the work of design supply, installation & commissioned ofNos. See-Saw water pumping system (.....Scheme) against various Sanction of Name of Agency at various locations in.....State, as per following details –

Capacity of water tank(Litre)	Particular	Year & Scheme	Total no. of System	Remarks
Total -				

This workmanship and performance of the above installed systems are found satisfactory and are in successful operation.

Seal & Sign
(Authorised Signatory)

Site Selection Form

FORM-A

Date : _____

Name of Village _____

Name of Block _____

Name of District _____

Location of Borewell _____

(eg. Distance from house owner, temple or any other landmark.) _____

Type of Existing Pump Hand Pump Submersible Pump None
 Diameter of Borewell 4 inch 6 inch other _____

Depth of Borewell as per record (eg. 30 mtrs.) _____ meters

Existing Depth of Borewell (eg. 30 mtrs.) _____ meters

Length of Casing Pipe (eg. 20 mtrs.) _____ meters

Yield of Borewell (Min, 2,500 lit/hr) _____ liters/hour

Static Water Level (eg. 10 mtrs.) _____ meters below ground level

Pumping Water Level (Max. 40mtrs. Where water Level is stable while pumping) _____ meters below ground level

Material Delivery Contact _____ Material Delivery
 (person to approach when detiv- $\frac{Name}{Mobile}$ Place (location to store
 erring equipment & material)

..... & its contractors are allowed to work for the installation of Solar Hand Pump System.

**Assistant Engineer/District Incharge
 CREDA, District Office**

**Beneficiary Department
 representative**

**Surveyor/Representative of
 Company**

 (Signature & Seal)

 (Signature & Seal)

 (Signature & Seal)

 Name

 Name

 Name

 Mobile number

 Mobile number

 Mobile number

FORM-B

Date : _____

Site Selection Criteria

Name of Village

Name of Block

Name of District

- Yield of the bore well should not be less than 2,500 liters/ hour
- Pumping Water Level should not be more than 40 meters.
- Identified bore well diameter should not be less than 100mm. or 4 inches.
- Water from the identified bore well should not be muddy at the depth at which the pump is expected to be installed.
- Tank tower location should not have any tree in the 10 meter periphery.
- The tank tower location should not have any transmission lines in the vicinity.
- Building structures more than 3 meters tall should not be near the tank tower location so that no shadow of any tree or house falls on the tank tower throughout the day.
- Distance between the stand post and tank tower should not be more than 15 meters and the distance between bore well and tank tower should not be more than 15 meters.
- The stand post location should have natural slope for drainage of accumulated water.

Assistant Engineer/District In charge b

Beneficiary Department

Surveyor/Representative of

CREDA, District Office

representative

Company

(Signature & Seal)

(Signature & Seal)

(Signature & Seal)

Name

Name

Name

Mobile number

Mobile number

Mobile number

END